

User Manual

Tektronix

Phaser® 300X
Color Printer

Copyright © Tektronix, Inc. Printed in the U.S.A.

Unpublished rights reserved under the copyright laws of the United States. Contents of this publication may not be reproduced in any form without permission of Tektronix, Inc.

This instrument, in whole or in part, may be protected by one or more U.S. or foreign patents or patent applications. Information provided upon request from Tektronix, Inc., P.O. Box 1000, Wilsonville, Oregon 97070-1000.

If acquired subject to FAR or DFARS, the following shall apply:

- Unpublished — rights reserved under the copyright laws of the United States.
- Restricted Rights Legend — Use, duplication, or disclosures by the U.S. government is subject to restrictions as set forth in subparagraph (c)(1)(ii) of the Rights in Technical Data and Computer Software clause at DFARS 252.227-7013, or in subparagraph (c) (2) of the Commercial Computer Software – Restricted Rights clause at FAR 52.227-19, as applicable. Tektronix, Inc., P.O. Box 1000, Wilsonville, Oregon 97070-1000.

Tektronix[®], Phaser[®], ColorStix[®], Made For Each Other[®], and ColorCoat[®] are registered trademarks of Tektronix, Inc. TekColor[™], Finepoint[™], PhaserPrint[™], and PhaserSym[™] are trademarks of Tektronix, Inc. TekColor CareSM is a service mark of Tektronix, Inc.

Adobe[®], Acrobat[®], Acrobat[®] Reader, Illustrator[®], Photoshop[®], and PostScript[®] are registered trademarks and Brilliant Screens[™] and IntelliSelect[™] are trademarks of Adobe Systems Incorporated or its subsidiaries which may be registered in certain jurisdictions.

The printer contains an implementation of the LZW algorithm licensed under U.S. Patent 4,558,302.

Apple[®], LaserWriter[®], LocalTalk[®], Macintosh[®], and TrueType2[®] are registered trademarks of Apple Computer, Incorporated.

Ethernet[™] is a trademark of Xerox Corporation.

Times[™], Helvetica[™], and Palatino[™] are trademarks of Linotype-Hell AG and/or its subsidiaries. ITC Avant Garde Gothic, ITC Bookman, ITC Zapf Chancery and ITC Zapf Dingbats are registered trademarks of International Typeface Corporation.

MS-DOS[®] and Windows[®] are registered trademarks of Microsoft Corporation.

Novell[®] and NetWare[®] are registered trademarks of Novell, Incorporated.

PCL5[®] is a registered trademark of Hewlett-Packard Corporation.

SPARC[®] is a registered trademark of SPARC International, Incorporated. SPARCstation[™] is a trademark of SPARC International, Incorporated, licensed exclusively to Sun Microsystems, Incorporated.

Sun[®], Sun Microsystems[®], and Sun Microsystems Computer Corporation[®] are registered trademarks of Sun Microsystems, Incorporated.

UNIX[®] is a registered trademark in the US and other countries, licensed exclusively through X/Open Company Limited.

Other marks are trademarks or registered trademarks of the companies with which they are associated.

PANTONE[®] Colors generated by the Phaser 300X Color Printer are four- and/or three-color process simulations and may not match PANTONE-identified solid color standards. Use current PANTONE Color Reference Manuals for accurate colors.

PANTONE Color simulations are only obtainable on this product when driven by qualified Pantone-licensed software packages. Contact Pantone, Inc. for a current list of qualified licensees.

All trademarks noted herein are either the property of Tektronix, Inc., Pantone, Inc., or their respective companies.

© Pantone, Inc., 1988.

Users safety summary

Terms in manual: CAUTION Conditions that can result in damage to the product.
WARNING Conditions that can result in personal injury or loss of life.

Power source: Do not apply more than 250 volts RMS between the supply conductors or between either supply conductor and ground. Use only the specified power cord and connector. Refer to a qualified service technician for changes to the cord or connector.

Operation of product: Avoid electric shock by contacting a qualified service technician to replace fuses inside the product. Do not operate without the covers and panels properly installed. Do not operate in an atmosphere of explosive gases.

Safety instructions: Read all installation instructions carefully before you plug the product into a power source.

Terms on product: CAUTION A personal injury hazard exists that may not be apparent. For example, a panel may cover the hazardous area. Also applies to a hazard to property including the product itself.
DANGER A personal injury hazard exists in the area where you see the sign.

Care of product: Disconnect the power plug by pulling the plug, not the cord. Disconnect the power plug if the power cord or plug is frayed or otherwise damaged, if you spill anything into the case, if product is exposed to any excess moisture, if product is dropped or damaged, if you suspect that the product needs servicing or repair, and whenever you clean the product.

Ground the product: Plug the three-wire power cord (with grounding prong) into grounded AC outlets only. If necessary, contact a licensed electrician to install a properly grounded outlet.

Symbols as marked on product:

DANGER high voltage:



Protective ground (earth) terminal:



Use caution. Refer to the manual(s) for information:



WARNING: If the product loses the ground connection, usage of knobs and controls (and other conductive parts) can cause an electrical shock. Electrical product may be hazardous if misused.

Phaser® 300X Warranty

Tektronix warrants that the **300X Color Printer** will be free from defects in materials and workmanship for a period of one (1) year from the date of shipment. If this product proves defective during its warranty period, Tektronix, at its option, will either repair the defective product without charge for parts and labor, or provide a replacement in exchange for the defective product.

This warranty applies only to products returned to the designated Tektronix depot or the Tektronix authorized representative from which the product was originally purchased. For products returned to other locations, Customer will be assessed an applicable service charge. The preceding limitation shall not apply within the European Economic Area, where products may be returned for warranty service to the nearest designated service depot regardless of the place of purchase.

In order to obtain service under this warranty, Customer must provide the applicable office of Tektronix or its authorized representative with notice of the defect before the expiration of the warranty period and make suitable arrangements for the performance of service. Customer shall be responsible for packaging and shipping the defective product to the service center designated by Tektronix or its representative, with shipping charges prepaid. Tektronix or its representative shall pay for the return of the product to Customer. Customer shall be responsible for paying any associated taxes or duties.

This warranty shall not apply to any defect, failure or damage caused by improper use or improper or inadequate maintenance and care. Tektronix shall not be obligated to furnish service under this warranty:

- a) to repair damage resulting from attempts by personnel other than Tektronix representatives to install, repair or service the product;
- b) to repair damage resulting from improper use or connection to incompatible equipment;
- c) to repair any damage or malfunction caused by the use of non-Tektronix supplies or consumables;
- d) to repair a product that has been modified or integrated with other products when the effect of such modification or integration increases the time or difficulty of servicing the product; or
- e) to repair damage or malfunction resulting from failure to perform user maintenance and cleaning at the frequency and as prescribed in the user manual (if applicable).

THE ABOVE WARRANTIES ARE GIVEN BY TEKTRONIX WITH RESPECT TO THIS PRODUCT IN LIEU OF ANY OTHER WARRANTIES, EXPRESS OR IMPLIED. TEKTRONIX AND ITS VENDORS DISCLAIM ANY IMPLIED WARRANTIES OF MERCHANTABILITY OR FITNESS FOR A PARTICULAR PURPOSE. TEKTRONIX' RESPONSIBILITY TO REPAIR OR REPLACE DEFECTIVE PRODUCTS IS THE SOLE AND EXCLUSIVE REMEDY PROVIDED TO THE CUSTOMER FOR BREACH OF THIS WARRANTY. TEKTRONIX AND ITS VENDORS WILL NOT BE LIABLE FOR ANY INDIRECT, SPECIAL, INCIDENTAL, OR CONSEQUENTIAL DAMAGES IRRESPECTIVE OF WHETHER TEKTRONIX OR THE VENDOR HAS ADVANCE NOTICE OF THE POSSIBILITY OF SUCH DAMAGES.

Contents

1 Introduction

2 Getting Set Up

At a glance 2-1

Checking the inventory 2-2

Setting up the printer 2-3

 Removing the shipping block 2-3

 Loading paper 2-4

 Installing the output tray 2-5

 Setting the media switch 2-6

Connecting the printer 2-7

 Printer ports 2-7

 LocalTalk connection 2-8

 Connecting the printer to a single computer using LocalTalk 2-9

 Ethernet connection 2-10

 Parallel connection 2-11

 Serial connection 2-12

 Turning on the printer 2-13

Selecting a language for the front panel 2-15

Making a test print 2-16

Installing software on your computer 2-17

Setting up PC ports (DOS) 2-18

 Parallel port setup 2-18

 Serial port setup 2-19

3 Printing

Which platform? 3-1

 Printing from a PC 3-1

 Using Windows printer drivers 3-2

 Using the printer's rear panel switches 3-2

 Using the Microsoft PostScript driver with Windows 95 3-4

 Using the AdobePS 4 driver with Windows 95 3-6

 Using the Adobe PostScript driver for Windows 3.1 3-8

Using the Windows NT PostScript driver	3-10
Printing from DOS	3-10
Printing from a Macintosh	3-11
Using Macintosh printer drivers	3-11
Using the printer's rear panel switches	3-11
Using the Phaser 300X driver	3-14
Using the Adobe PSPrinter Driver	3-14
Using the Phaser 300X GX driver	3-15
Printing from a workstation	3-16
Overview	3-16
UNIX workstations	3-17
VMS workstations	3-18
For more information	3-18
Printing from specific applications	3-19
General hints and tips	3-19
Windows applications	3-19
Aldus PageMaker and FreeHand	3-19
Adobe PageMaker	3-19
Macromedia FreeHand	3-19
QuarkXPress	3-19
Pantone	3-19
Macintosh applications	3-20
QuarkXPress	3-20
Adobe Photoshop	3-20
Pantone	3-20
Other applications	3-20
Selecting print features	3-21
Print modes	3-21
Print-quality modes	3-21
Finepoint Sharpening	3-21
Color correction	3-22
Color Control Strip feature	3-23
All about media	3-24
Grade and finish	3-24

- Size 3-25
- Weight and thickness 3-26
- Grain 3-27
- Margins and image area 3-28
 - Image area for Tabloid Extra 3-29
 - Image area for color prints 3-29
- Image orientation 3-30
- Media handling 3-31
- Using the paper trays 3-32
 - Loading letterhead 3-33
 - Loading three-holed paper 3-33
- Using manual feed 3-34
 - Inserting the paper 3-34
 - Manual feed examples: paper, envelopes 3-35
- Making transparencies 3-36
- Fonts 3-37
 - Resident typefaces (PostScript) 3-37
 - Resident typefaces (PCL5) 3-38
 - Downloading Macintosh and TrueType fonts 3-38
 - Installing Macintosh screen fonts 3-39
- Printer languages: PostScript, HP-GL, PCL5 3-40
 - Switching printer languages 3-41
 - Printing with PCL5 3-42
 - Printing with HP-GL 3-42
 - Printing PostScript 3-42
 - Changing the HP-GL default settings 3-43

4 Caring for Your Printer

- Overview 4-1
- Adding ink 4-2
- Changing the fuser wiper 4-4
- Emptying the waste bin 4-5
 - Emptying the waste bin when front panel message displays 4-6
 - Emptying the waste bin before moving the printer 4-7

Cleaning the printer	4-8
New printer cleaning supplies	4-8
Reorder cleaning kit supplies	4-9
Using isopropyl alcohol	4-10
Cleaning the paper-pick rollers	4-11
Cleaning the feed rollers	4-12
Cleaning the paper tension blade, paper clamp, and drum	4-13
Cleaning the head wiper	4-20
Cleaning the fuser rollers	4-22
Quick Steps	4-22
Procedure A	4-24
Procedure B	4-25

5 Supplies and Accessories

Tektronix supplies: the mark of quality	5-1
Ordering information	5-1
Upgrade kits	5-3
Interface cables and Ethernet adapters	5-4

6 Troubleshooting

If you need help	6-1
Using the automated fax systems	6-2
Error codes and front panel messages	6-3
Clearing paper jams	6-5
Removing jammed paper	6-6
Removing a paper jam from the rear of the printer	6-7
Setting head convergence	6-8
Test print example	6-8
General cleaning guide	6-12
Problems, solutions, hints	6-13
Print quality problems	6-13
Network problems	6-20
Operation hints	6-21
Printer standby modes	6-23
Printing and installation	6-24

7 Front and Rear Panels

- Front panel 7-2
 - Utilities mode menu structure 7-4
- Rear panel 7-5
 - Rear panel switches 7-5
 - Rear-panel LED indicator 7-6

A Technical Notes

- Startup and configuration pages A-1
 - Turning off the startup page A-1
 - Generating a configuration page A-2
 - Print count A-3
- Printer ports A-4
 - LocalTalk and Ethernet ports A-4
 - Printer name and AppleTalk zones A-4
 - Parallel port A-5
 - Serial port A-6
 - Serial port signals A-8
- Specifications A-9
- Safety and emissions A-10

B Expanding Your Printing System

- Customizing your printer B-1
- Extended features upgrade B-1
- Upgrades kits B-2
 - Advantages of adding memory B-3
- PhaserPrint B-4
- PhaserSym B-4
- Adding a hard disk for font storage B-5
 - Connecting one disk B-7
 - Connecting multiple disks B-8

C **Moving Your Printer**

Reinstalling the shipping block C-2

Changing line voltage C-4

D **Regulatory Information**

Declaration of conformity D-1

Canadian EMC (Electromagnetic Compatibility)
regulatory standards D-2

FCC Class B warning (for 115 VAC equipment) D-2

Material Safety Data Sheets D-3

Index

Introduction

The Tektronix Phaser 300X Color Printer uses Tektronix' solid ink-jet technology. Solid ink-jet refers to the melting of the solid inks inside the printer, which then resolidify on paper. The ink resolidifies so rapidly that it does not have time to bleed into the paper, so the printed colors remain brilliant and well-defined.

With the Phaser 300X, you can use almost any kind of paper, such as Bond, Book, Cover, and Text, as well as transparency film.

Standard configuration. In its standard configuration, the printer provides 10 Mbytes of memory, a total of 39 fonts, and prints on media as large as 11 x 17 in. (297 x 420 mm). Additional memory for improved performance is optionally available.

Extended Features option. The Extended Features option, the recommended configuration, provides the following features and capabilities:

Feature	Capabilities
Additional 12 Mbytes of RAM (for a total of 22 Mbytes)	<ul style="list-style-type: none"> ■ Full Tabloid-bleed image area on Tabloid Extra media (305 x 457-mm, 12 x 18 in.) ■ Allows printing of complex documents ■ Faster printing and file downloading ■ Maximum throughput in networked workgroups ■ Optimum Photoshop performance via a custom plug-in ■ Monochrome PCL5 (must be enabled)
Ethernet connectivity	<ul style="list-style-type: none"> ■ EtherTalk, Novell, TCP/IP
PhaserMatch™ custom profiler	<ul style="list-style-type: none"> ■ Custom color matching for the greatest accuracy and consistency in printed colors
Supplies Startup Kit	<ul style="list-style-type: none"> ■ 8 ColorStix ink sticks of each color ink

Language support. The Phaser 300X lets you make color prints from a variety of software applications since it incorporates Adobe's PostScript Level 2 software and accepts Hewlett-Packard Graphics Language (HP-GL) files and monochrome PCL5 (Printer Command Language) files (PCL5 is optionally available). The Phaser 300X printer interfaces can be set (by using an automatic language selection PostScript utility file) to automatically switch between all three supported languages: PostScript, HP-GL, and PCL5. The default language is PostScript.

Network printing. The printer works with Macintosh computers, PCs, UNIX workstations, and VMS workstations, making it a resource that can be shared in mixed environments. You can connect one host or several hosts to the printer because it supports simultaneous input through parallel, serial, and LocalTalk, and the optional Ethernet interface with support for EtherTalk, Novell NetWare, and TCP/IP protocols.

Font support. Besides its 39 resident fonts, the printer accepts Adobe Type 1 and Type 3 downloadable fonts, TrueType fonts, optional PCL5, and a variety of user-defined fonts. You can download additional fonts as needed, or store them on an external hard disk.

Excellent color control. TekColor Dynamic Correction provides built-in color correction modes for simulating SWOP (Specifications for Web Offset Publications), SNAP profile (for creative work designed to print on newsprint), Commercial Press (matching commercial Matchprint[®] proofs), and Euroscale Press (matching the *Pantone Process Color System Guide, Euroscale*). SWOP Press is a set of specifications for color separation films and color proofing used to ensure the consistency of printed colors between different publications.

With the Extended Features option, you get the **PhaserMatch color profiler**, which allows you to adjust printed colors for a specific press, paper, and ink, providing the greatest accuracy and consistency. This feature is invaluable for graphics professionals who want full control of the color process.

PhaserMatch software for the Macintosh and PC platforms provides a simple approach for creating and editing color profiles. It is designed for the most demanding users who need to consistently and accurately predict and control colors. The profiles are created by adjusting dot gain, controlling density or color reproduction curves to simulate the color output of a particular press or other industry standard systems.

The printer software also includes the **Color Control Strip** feature, which allows you to check the consistency of printed colors between prints made on the same printer, as well as between prints made on more than one of the same type or model of printer. When this option is selected in the printer driver, the printed page includes a band of colors along the bottom edge; the colors in this band reflect the currently selected color correction.

PANTONE[®] support. When you use the printer with software applications that support PANTONE Colors, the printer produces Pantone-approved process color simulations. The software application provides the process color values used to approximate PANTONE Colors. The Phaser 300X CD-ROM and diskettes include a sampler chart of process color values, which are optimized for the Phaser 300X. You can also retrieve this information from Tektronix' World Wide Web server at www.tek.com.

Print quality and speed. The Phaser 300X has 300 dots-per-inch resolution and a print speed of 1 to 4 minutes per Letter-sized page, depending on the print quality mode. Print quality modes include Standard, Enhanced, and Premium.

Media support. The printer produces laser-quality prints on paper ranging from 100 x 150 mm (4 x 6 in.) to 305 x 457 mm (12 x 18 in.). The printer has 10 Mbytes of standard memory, expandable in 4-Mbyte increments to 22 Mbytes. With the standard memory configuration, the maximum printable area is 287 x 408 mm for A3-size media and 10.5 x 16.5 in. for B-size media. When you expand memory to 14 Mbytes, you can print Tabloid-size bleed images (297 x 445 mm, 11.7 x 17.5 in.) on Tabloid Extra paper (305 x 457-mm, 12 x 18 in.).

Easy to use and maintain. When the printer needs ink, you just drop in solid ColorStix ink. Each ColorStix ink stick is a unique shape so that you always load the correct color into the correct ink bin.

To order supplies such as paper or ColorStix ink, refer to the supplies information sheet that is shipped with the printer and contact your local dealer or, in the United States, call Tektronix at **1-800-835-6100**. You can also retrieve this information from Tektronix' World Wide Web server at **www.tek.com**.

Getting Set Up

At a glance

Installation of your Phaser 300X Color Printer involves these tasks:

- 1. Checking the inventory**
- 2. Setting up the printer**
 - Removing the shipping block
 - Loading paper
 - Installing the output tray
 - Setting the media switch
- 3. Connecting the printer**
 - Connecting all cables: serial, parallel, LocalTalk, Ethernet, SCSI, and power.
- 4. Selecting a language for the front panel**
- 5. Installing software on your computer**
- 6. Setting up PC ports (DOS)**
 - Serial port setup
 - Parallel port setup

Checking the inventory

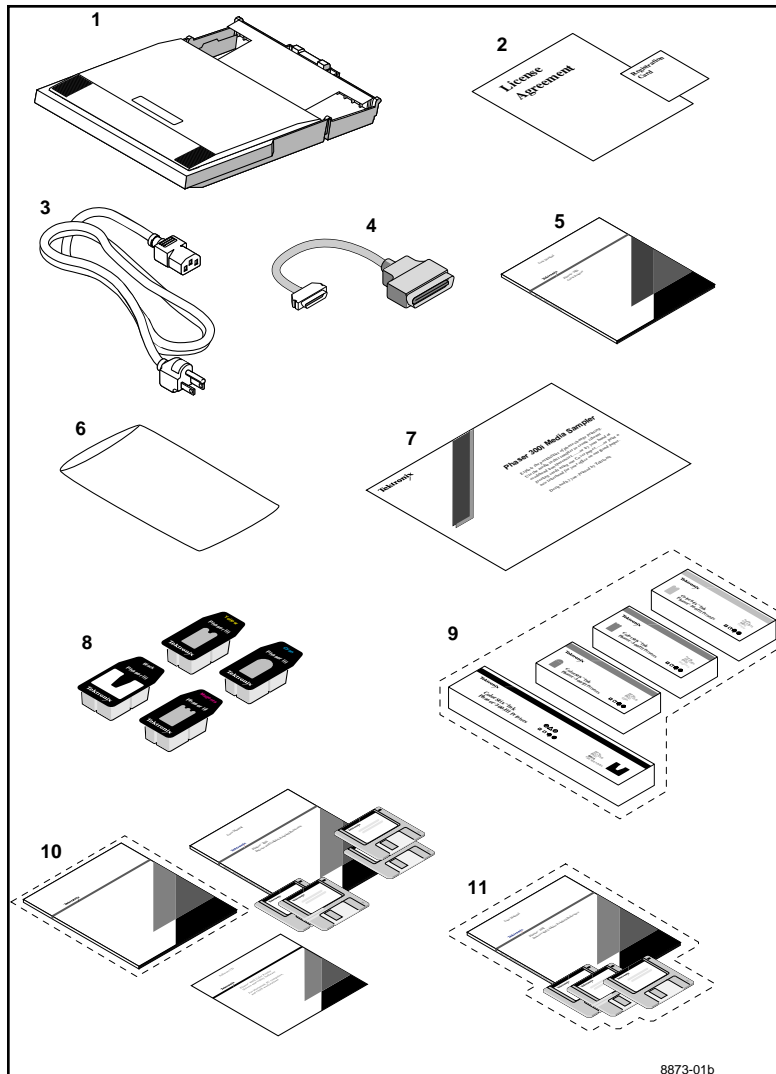

1. Universal media tray
2. Registration card and license agreement
3. Power cord
4. Parallel cable adapter
5. Phaser 300X Color Printer User Manual
6. Cleaning kit
7. Phaser 300X Media Sampler
8. Individual ColorStix ink sticks
9. An extra box of each color of ColorStix ink (optional)
10. The *Phaser 300X Drivers and Utilities Printing Reference* manual, CD-ROM, diskettes, and (optional) PhaserMatch documentation
11. *Network Utilities for Phaser Color Printers User Manual* and diskettes (optional)

See “Interface cables and Ethernet adapters” on page 5-4 for information on purchasing interface cables, LocalTalk adapters, and Ethernet adapters.

Note Save all boxes and packing material in case moving or subsequent shipment is necessary.

Setting up the printer

Note *The printer is shipped to you already loaded with ink. You do not need to add any ink when you first set up the printer.*

Removing the shipping block

1. Open the top cover.
2. Hold down the button while you open the rear cover.
3. Push the shipping block tab up and slide it, along with the printhead, past the post.
4. Remove the shipping block, then close the covers.

Note *Save the shipping block to use again if you move the printer; the shipping block protects the printhead.*

Save all boxes and packing material in case moving or subsequent shipment is necessary.

Caution *You must remove all packing material before turning the printer on; otherwise you will damage the printhead.*

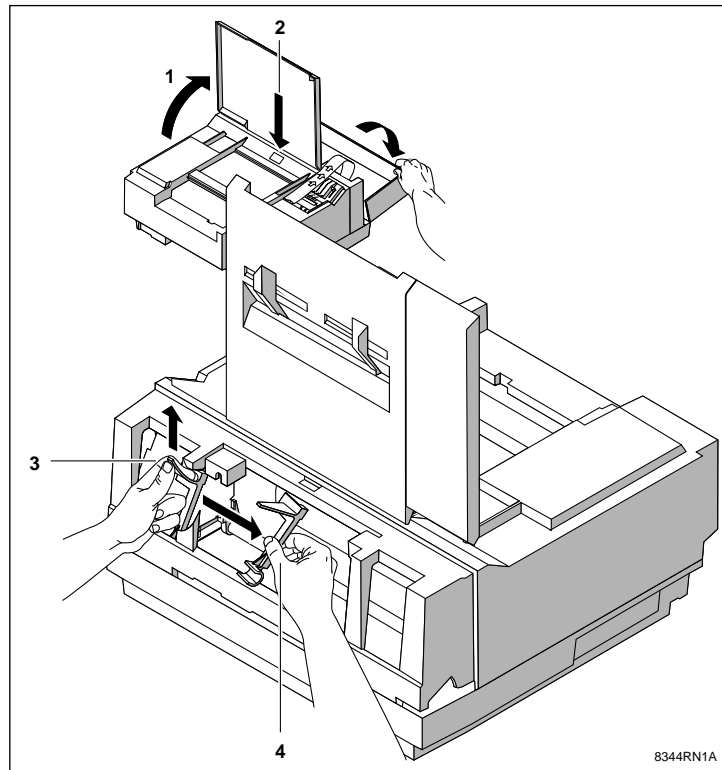

Loading paper

1. Move the guides.
2. Push down on the metal lift plate with your finger; then slide the paper under the tabs. When you use A-size (8.5 x 11 in.) or A4-size (210 x 297 mm) paper, place the long side of the paper under the tabs, making sure that the paper fits snugly against the inside front wall of the paper tray.
3. Adjust the rear guide until it touches the rear of the paper.

Note *The rear guide must fit snugly against the paper; otherwise the printed image might be clipped or rotated.*

4. Put the cover on the paper tray.
5. Insert the paper tray into the printer. Tilt the paper tray up slightly as you insert it.

Note *To load transparencies, refer to "Making transparencies" on page 3-36.*

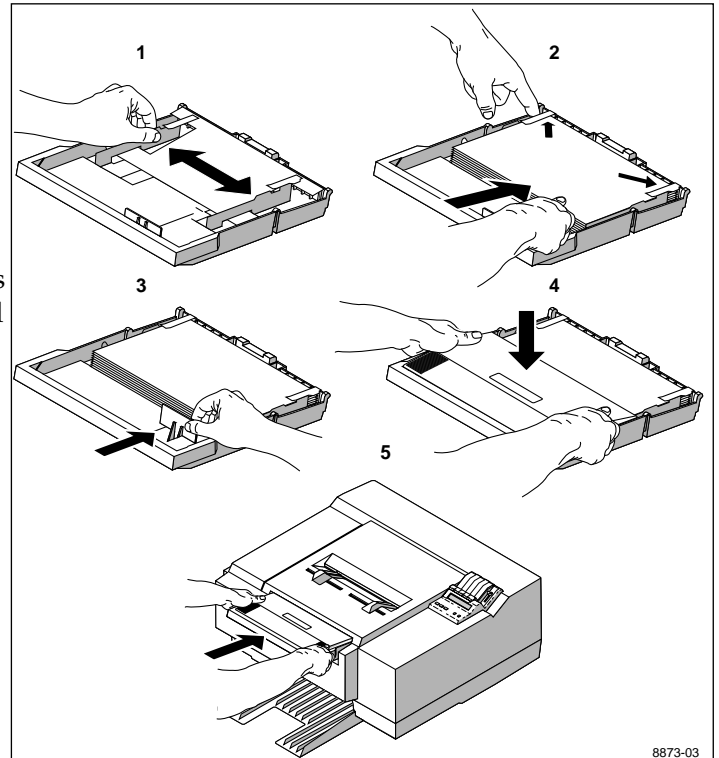

Installing the output tray

1. Push the output tray into the lower slot until it clicks into place.
2. Fit the rear tab into the slot inside the printer. The tabs on the sides of the tray fit into the slots on the sides of the printer.

If you need to remove the tray, press in on both sides of the tray next to the tabs while you pull out the tray.

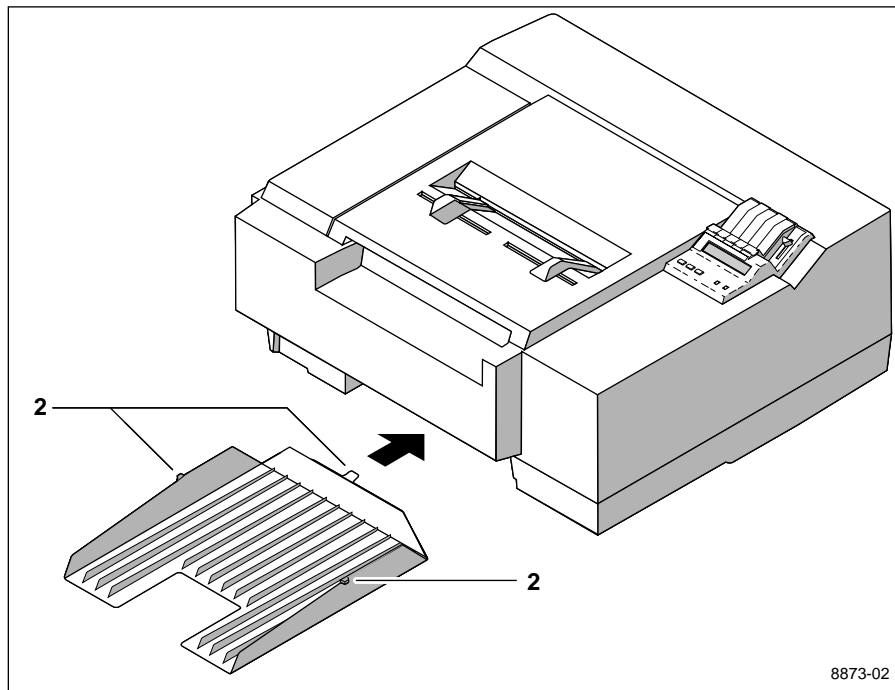

Setting the media switch

Set **Switch 6** for the paper size:

- *Down* for American-size paper
- *Up* for Metric-size paper

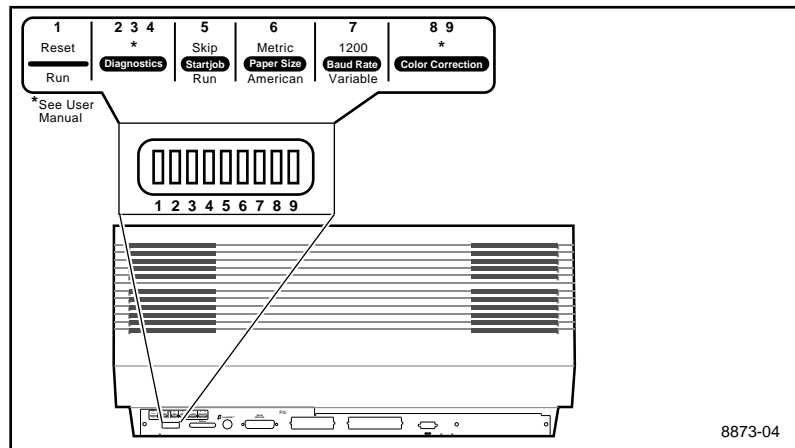

The default setting for all switches is *down*. Unless you are using the serial port, the only switch you have to set is **Switch 6** for the media size. Refer to “Rear panel” on page 5 for details on all the switches.

Connecting the printer

Printer ports

The printer accepts data through four ports:

1. LocalTalk
2. Serial (RS-232)
3. Parallel
4. Ethernet

The printer accepts data from all the ports at the same time. The printer accepts print jobs on a first-come, first-served basis.

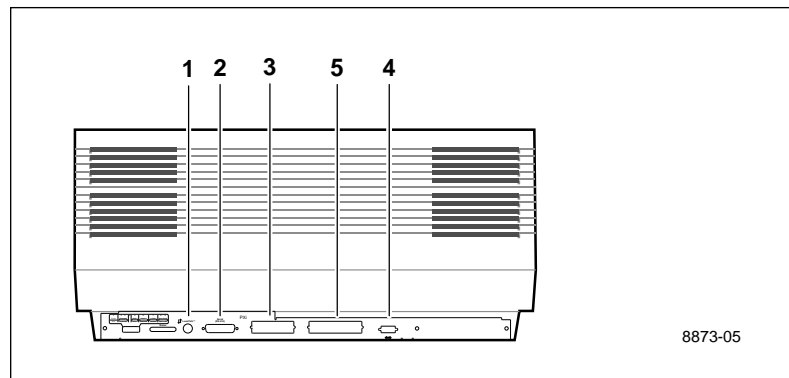

The SCSI port (5) is for connecting an external hard disk only. You cannot connect a computer to this port or send print data through the SCSI interface. Refer to “Adding a hard disk for font storage” on page B-5 for more information on the SCSI port.

Note See “Interface cables and Ethernet adapters” on page 5-4 about ordering cables and adapters for connecting the printer.

LocalTalk connection

You can make LocalTalk connections between the printer and a single computer or on a LocalTalk network using a *daisy-chain* or *star* setup. If your LocalTalk installation is complex, or if you need assistance, contact your network system administrator.

Note *LocalTalk is sometimes referred to as AppleTalk. LocalTalk refers to the physical connection; AppleTalk is the set of protocols.*

LocalTalk connectors and cables are available through your dealer. The illustration shows two commonly used types of LocalTalk connectors:

1. Self-terminating connector.
2. Connector that requires an external terminator (depending on your network configuration).

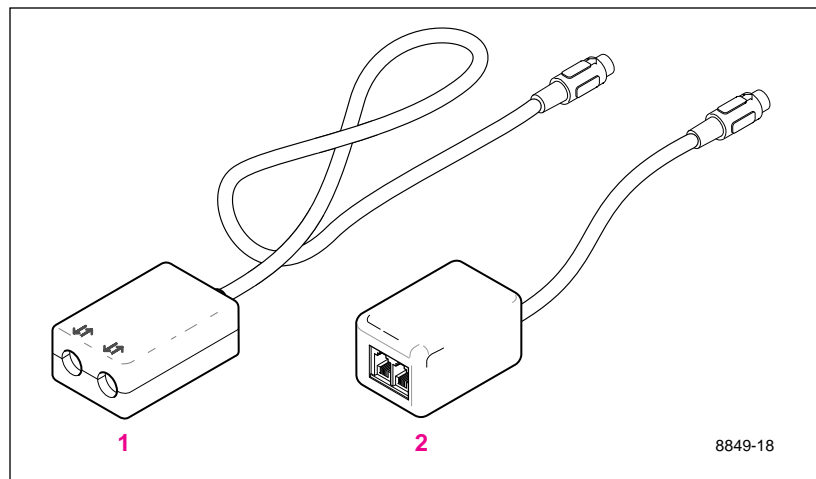

Note *Depending on the type of LocalTalk cables you use and your network configuration, you may need to use terminators at certain points in the installation. Refer to the documentation for your LocalTalk connectors and cables for details.*

Connecting the printer to a single computer using LocalTalk

You can use LocalTalk connectors and cables to connect the printer directly to your computer, without connecting it to any other network.

Note *If your network consists of a single Macintosh and printer and the cable you are using is not self-terminating, you need to terminate both ends of the network.*

1. Turn the printer *off* before making any LocalTalk connections.
2. Connect the short cable of a LocalTalk connector to the printer's LocalTalk port.
3. Connect the short cable of a second LocalTalk connector to your computer's LocalTalk port.
4. Connect a LocalTalk cable between the two LocalTalk connectors you have just attached to your computer and your printer.

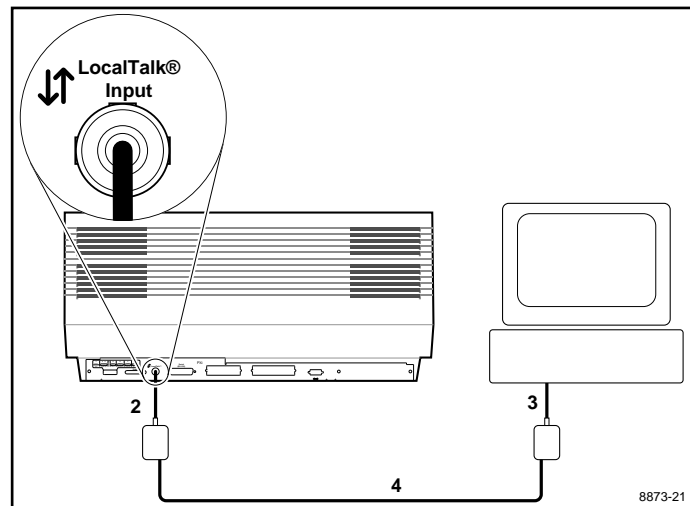

If you have no other connections to make, read ahead to “Turning on the printer” on page 2-13.

Ethernet connection

Ethernet is a communication standard that supports high-speed data transmission — up to 10 times faster than LocalTalk. If you ordered your printer with the network option, you received the Network Utilities diskettes and the *Network Utilities for Phaser Color Printers User Manual*. For complete information on Ethernet (including setup), refer to that manual.

Parallel connection

High-density parallel connector

The printer uses a 1284C-compliant high-density parallel connector for connection to parallel devices. A parallel cable adapter, included with the printer, converts a standard 36-pin low-density parallel cable plug to a 36-pin high-density plug. The adapter is used when connecting a standard Centronics parallel cable to the printer's high-density parallel connector. Parallel cables are available from Tektronix; refer to "Interface cables and Ethernet adapters" on page 4.

1. Connect a parallel interface cable to your computer and to the printer's parallel port.

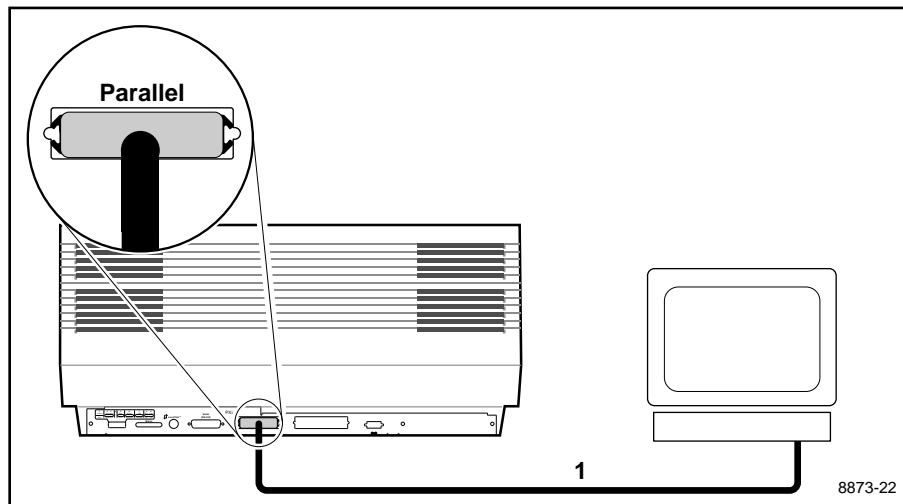

If you have no other connections to make, read ahead to "Turning on the printer" on page 2-13.

Note *If your computer is a PC: After you turn on the printer and install software on your PC, you must set up your PC's parallel port to match the settings you have selected for the printer's parallel port. Refer to "Installing software on your computer" on page 17 for Windows or "Setting up PC ports (DOS)" on page 2-18 for DOS.*

Serial connection

9-pin serial connector

The printer uses a 9-pin serial plug on the rear panel for connection to serial devices. Both 9-socket to 9-socket and 9-socket to 25-socket null-modem serial cables are available from Tektronix; refer to “Interface cables and Ethernet adapters” on page 4.

Note Use a “null-modem” serial cable. An ordinary serial cable may cause communication problems. You can purchase null-modem cables from Tektronix. Refer to “Interface cables and Ethernet adapters” on page 5-4.

1. Connect a serial interface cable to your computer and to the printer’s serial port.
2. Set the **Baud Rate** switch, **Switch 7**, on the rear panel:
 - Set **Switch 7** down for a variable baud rate. (The default baud rate is 9600, the fastest rate available on this port; to change the baud rate to a setting other than 9600, refer to the *Phaser 300X Drivers and Utilities Printing Reference*.)
 - Set **Switch 7** up for a fixed baud rate of 1200.

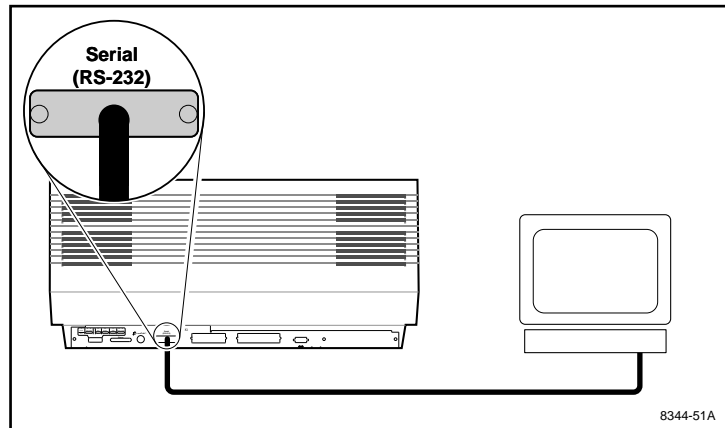

Note If your computer is a PC: After you turn on the printer and install software on your PC, you must set up your PC’s serial port to match the settings you have selected for the printer’s serial port. Refer to “Installing software on your computer” on page 17 for Windows or “Setting up PC ports (DOS)” on page 2-18 for DOS.

Turning on the printer

Caution To avoid damaging the printer, make sure that you have removed all packing material before turning on the printer.

Make sure that the voltage select switch is set to match the AC line voltage and that the power switch is in the **off** position before connecting the power cord.

1. Plug the power cord into the printer and into a grounded outlet.

Note If you are connecting any peripherals such as a SCSI hard disk, plug it in and turn it on before turning on the printer.

2. Turn on the printer.

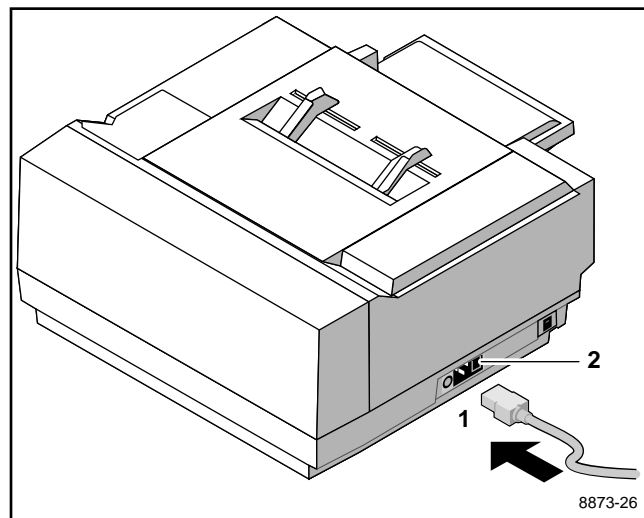

Caution To avoid damaging the printer, do not turn the printer off when the front panel displays any of the following messages: "Busy Cleaning Head," "Printing," or "Utilities," unless you turn the printer on again within 5 minutes.

When you turn on the printer, the **POWER** and **ERROR** indicators on the front panel light up. The printer takes about 15 to 20 minutes to warm up and complete a series of self-tests. During the warm-up cycle, the **POWER** indicator remains on; the **ERROR** light goes out.

After the self-tests run successfully, the printer prints a startup page. The startup page prints whenever you turn on or reset the printer. If you want to turn off the startup page, you can use a utility file provided on the Phaser 300X CD-ROM and diskettes. Refer to “Turning off the startup page” on page A-1 and the *Phaser 300X Drivers and Utilities Printing Reference* for details on using the utility file.

Note *You should leave the printer on if you use it frequently (such as during a normal work week with daily use). The printer has an automatic standby mode that keeps the printer ready to use and reduces energy consumption. If the printer will be idle for two days or more (such as over a weekend), turn it off.*

Selecting a language for the front panel

Messages that appear in the front panel window are in English. You can leave the front panel set to English or change the language to French, German, Spanish, Italian, or Japanese.

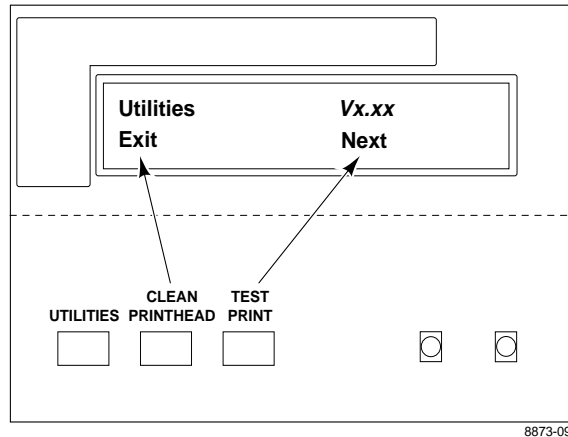

1. When the printer is on and the Ready message appears, press the **UTILITIES** button. You see this message (*Vx.xx* is the firmware version number):

```
Utilities    Vx.xx
Exit        Next
```

In the **Utilities** mode, you can scroll through the menu selections using the **TEST PRINT** button. The **CLEAN PRINT HEAD** button allows you to execute a function or change a setting.

2. Press the **TEST PRINT** button (**Next**) twice to scroll to the language selection mode. You see this message:

```
Language:   English
Change     Next
```

3. Press the **CLEAN PRINT HEAD** button (**Change**) to change the language selection:

- Press one time = German
- Press two times = French
- Press three times = Italian
- Press four times = Spanish
- Press five times = Japanese

4. Press the **TEST PRINT** button 5 times to return to the **Utilities** mode. The message appears in whichever language you selected:

```
Utilities    Vx.xx
Exit        Next
```

5. Press the **CLEAN PRINT HEAD** button (**Exit**) to exit the **Utilities** mode. The front panel displays the Ready message.

Making a test print

To make a test print, make sure that the front panel display shows the Ready message, then press the **TEST PRINT** button on the printer's front panel.

Installing software on your computer

Packaged with your printer are the Phaser 300X CD-ROM and diskettes that contain utilities, drivers, PPDs, and other useful files.

For complete details on the contents of the Phaser 300X CD-ROM and diskettes and how to install the software, refer to *Phaser 300X Drivers and Utilities Printing Reference*, which is shipped with the printer.

To select print features in a driver, refer to “Selecting print features” on page 3-21 and the *Phaser 300X Drivers and Utilities Printing Reference*.

For workstation users, the CD-ROM includes a demonstration copy of the PhaserPrint software. PhaserPrint provides a graphical user interface in which to select print features such as color correction and print quality mode. Refer to “Printing from a workstation” on page 3-16 for more information on using PhaserPrint; refer to page 5-1 for order information.

Workstation users can also use the utility files on either the CD-ROM or the PC diskettes, or download utilities and files from the Tektronix Bulletin Board System (BBS) or get files from the Tektronix Color Printer Information Server. Refer to “Online services” on page 6-1.

Setting up PC ports (DOS)

Parallel port setup

If your computer is a PC running DOS and you are using the printer's parallel port, use the DOS **MODE** command to disable timeouts on your computer's parallel port to ensure that large files will print, even if data transmission is slow.

1. Type the following command at the DOS prompt (if LPT1 is not available, use LPT2):

```
MODE LPT1:,,P > NUL
```

See your DOS documentation for details on the **MODE** command.

2. You can add the **MODE** command to your **AUTOEXEC.BAT** file so that it takes effect every time you turn on your computer. (Refer to your PC user documentation.)

Serial port setup

If your computer is a PC using DOS and you are using the serial port, you must set up your computer's serial port parameters to match the settings you made on the printer's serial port.

Under DOS, use the **MODE** command to set up your computer's serial port:

Note *Switch 7 must be **down** for the variable baud rate operation.*

1. If you set the printer's rear panel **Baud Rate** switch (**Switch 7**) *down* for variable baud rate and you are using the default serial parameters for this position, type the following command at the DOS prompt (if COM1 is not available, use COM2):

MODE COM1:9600,N,8,1,P

If you changed the printer's serial port parameters from the defaults, you must enter different values for the **MODE** command (see your DOS documentation for details on the **MODE** command).

If you set the printer's rear panel **Baud Rate** switch (**Switch 7**) *up* for a fixed baud rate of 1200, enter this command (if COM1 is not available, use COM2):

MODE COM1:1200,N,8,1,P

Refer to "Serial port" on page A-6 for a complete listing of the printer's default serial port parameters.

2. You can add the **MODE** command to your *AUTOEXEC.BAT* file, so that it takes effect every time you turn on your computer. (Refer to your PC user documentation.)

Your Phaser 300X is now ready to use. If you want to turn on or turn off the startup page, refer to "Turning off the startup page" on page A-1. Refer to "Adding a hard disk for font storage" on page B-5 if you want to add a hard disk.

Printing

Which platform?

You can print to your printer from IBM-compatible personal computers, Macintosh computers, and workstations. Make sure your printer is set up with the appropriate interface port; refer to “Connecting the printer” on page 2-7.

Note *If you haven't already installed the printer's software, refer to **Phaser 300X Drivers and Utilities Printing Reference** for instructions before continuing.*

Printing from a PC	■ Windows 95	see page 3-4
	■ Windows 3.1	see page 3-8
	■ Windows NT	see page 3-10
Printing from a Macintosh	■ Phaser 300X Driver	see page 3-14
	■ Adobe PSPrinter Driver 8.3.1	see page 3-14
	■ Phaser 300X GX Driver	see page 3-15
Printing from a workstation		see page 3-16

Printing from a PC

You can print from a PC with or without a printer driver. The supported drivers allow you to select printing features right from your computer. Without a supported driver, you can make some printing selections with the rear panel switches; you can also use custom downloaded utility files that are available on the printer's CD-ROM, diskettes, or from the Tektronix World Wide Web server.

Using Windows printer drivers

To select printer-specific features, print from one of the following provided drivers. Refer to the Windows “Print features quick reference” table on this page for a list of the printing features and how to find them quickly in each of these drivers.

Windows 95 (Microsoft PostScript driver)	see page 3-4
Windows 95 (AdobePS 4 driver)	see page 3-6
Windows 3.1 (AdobePS 3 driver)	see page 3-8
Windows NT (PostScript driver)	see page 3-10

Using the printer's rear panel switches

Refer to “Rear panel switches” on page 7-5 for instructions on changing the color correction mode with the rear panel switches. Refer to the *Phaser 300X Drivers and Utilities Printing Reference* for detailed information on using the rear panel switches to change other print features.

Print features quick reference: Windows printer drivers

Feature	Feature descriptions	Windows 3.1 AdobePS 3 PostScript driver	Windows 95 Microsoft PostScript driver and AdobePS 4 PostScript driver
Print-quality modes <ul style="list-style-type: none"> ■ Standard ■ Enhanced ■ Premium 	See page 3-21	Features tab ↳ Print Quality	Properties ↳ Device Options tab ↳ Printer features ↳ Print Quality
Color correction <ul style="list-style-type: none"> ■ Vivid Color ■ None ■ Simulate Display ■ SWOP Press ■ Euroscale Press ■ Commercial Press ■ SNAP Press ■ Monochrome ■ Use Printer Settings ■ Custom Profile*† 	See page 3-22	Features tab ↳ Color Correction	Properties ↳ Device Options tab ↳ Printer features ↳ Color Correction

* These features are available with the printer's Extended Features option only.

† Selecting Custom Profile displays another list showing the profiles that you created in PhaserMatch. Not available in the Microsoft PostScript driver.

Print features quick reference: Windows printer drivers (cont'd.)

Feature	Feature descriptions	Windows 3.1 AdobePS 3 PostScript driver	Windows 95 Microsoft PostScript driver and AdobePS 4 PostScript driver
Media size <ul style="list-style-type: none"> ■ Letter ■ Legal ■ Tabloid ■ Letter Extra ■ Tabloid Extra ■ A4 ■ A3 ■ 4x6 Card ■ 5x7 Card ■ A5 ■ A6 ■ ISOB4 ■ ISOB5 ■ ISOB6 ■ Compliment Slip ■ #10 Envelope ■ C6 Envelope ■ DL Envelope ■ A4 Envelope ■ .5 A4 Envelope 	See page 3-25	Paper tab ↳ Paper Size	Properties ↳ Paper tab ↳ Paper Size
Media source <ul style="list-style-type: none"> ■ Media Tray ■ Manual Feed 	See page 3-32	Paper tab ↳ Paper Source	Properties ↳ Paper tab ↳ Paper Source
Finepoint Sharpening <ul style="list-style-type: none"> ■ On ■ Off 	See page 3-21	Features tab ↳ Finepoint Sharpening	Properties ↳ Device options tab ↳ Printer features ↳ Finepoint Sharpening
Color Control Strip <ul style="list-style-type: none"> ■ On ■ Off 	Refer to the <i>Phaser 300X Drivers and Utilities Printing Reference</i>	Features tab ↳ Color Control Strip	Properties ↳ Device options tab ↳ Printer features ↳ Color Control Strip

* These features are available with the printer's Extended Features option only.

† Selecting Custom Profile displays another list showing the profiles that you created in PhaserMatch. Not available in the Microsoft PostScript driver.

Using the Microsoft PostScript driver with Windows 95

To select printing options, follow these steps:

1. In the **Printers** window, click the **Phaser 300X** printer icon with the right mouse button, then select **Properties** from the menu.
2. Click the following tabs to see printing options; refer to your Windows 95 documentation for more information on tabs and options.
 - Click the **Details** tab to see timeout and other options.
 - Set the **Timeout settings**.

Not Selected: Type a value of **0**, or between **15** and **999**, in this text box to change the number of seconds Windows waits before notifying you that a printer is off-line. The default is **15** seconds.

Transmission Retry: On large or multiple-page documents you may see an Alert message that the printer is no longer accepting data before the job is completely sent to the printer. When using a shared printer, you should set this option to a larger value, such as **900 seconds** (15 minutes) to avoid these unnecessary timeouts. Type a value between **45** and **999** in this text box; the default setting is **45** seconds. (If you are having timeout problems, refer to the on-line manual on the printer's CD-ROM for information on setting the printer's timeout.)

- Click the **Paper** tab to see media options, such as media sizes and types.
- Click the **Graphics** tab to see graphics options.

Note *If you are using host color correction, you need to make selections in the **Graphics** and **Device Options** tabs. Refer to the **Phaser 300X Drivers and Utilities Printing Reference** for more information on host color correction.*

- Click the **Device Options** tab to see printer-specific options, such as color corrections.
- Click the **PostScript** tab to see PostScript-related options.
 - The PostScript header contains important PostScript information that must accompany each print job; it is not a banner page printed with each job. If an option is not selected, an error message is displayed on your computer screen and your job does not print. Click one of the following in the **PostScript header** field:

Select **Download header with each print job**. This option downloads PostScript header information with each print job.

Click the **Send Header Now** button to save the PostScript header information in the printer, then select the **Assume header is downloaded and retained** option. This option makes print files a little smaller and faster than the first option, but you need to click the **Send Header Now** button every time the printer is turned off or reset.
 - Click the **Advanced** button to see more options. Select **Use PostScript Level 2 features**. Click **OK** when finished.

Note *For faster printing, select **Binary communications protocol** under **Data format**.*

Using the AdobePS 4 driver with Windows 95

To select printing options, follow these steps:

1. In the **Printers** window, click the **Phaser 300X** printer icon with the right mouse button, then select **Properties** from the menu.
2. Click the following tabs to see printing options; refer to your Windows 95 documentation for more information on tabs and options.
 - Click the **Details** tab to see timeout and other options.
 - Set the **Timeout settings**.

Not Selected: Type a value of **0**, or between **15** and **999**, in this text box to change the number of seconds Windows waits before notifying you that a printer is off-line. The default is **15** seconds.

Transmission Retry: On large or multiple-page documents you may see an Alert message that the printer is no longer accepting data before the job is completely sent to the printer. When using a shared printer, you should set this option to a larger value, such as **900 seconds** (15 minutes) to avoid these unnecessary timeouts. Type a value between **45** and **999** in this text box; the default setting is **45** seconds.

- Click the **Paper** tab to see media options, such as media sizes and media types.
- Click the **Graphics** tab to see graphics options.

Note *If you are using host color correction, you need to make selections in the **Graphics** and **Device Options** tabs. Refer to the **Phaser 300X Drivers and Utilities Printing Reference** for more information on host color correction.*

- Click the **Device Options** tab to see printer-specific options, such as color corrections.
- Click the **PostScript** tab to see PostScript-related options.
 - The PostScript header contains important PostScript information that must accompany each print job; it is not a banner page printed with each job. If an option is not selected, an error message is displayed on your computer screen and your job does not print. Click one of the following in the **PostScript header** field:

Select **Download header with each print job**. This option downloads PostScript header information with each print job.

Click the **Send Header Now** button to save the PostScript header information in the printer, then select the **Assume header is downloaded and retained** option. This option makes print files a little smaller and faster than the first option, but you need to click the **Send Header Now** button every time the printer is turned off or reset.
 - Click the **Advanced** button to see more options. Select **Use PostScript Level 2 features**. Click **OK** when finished.

Note *For faster printing, select **Binary communications protocol** under **Data format**.*

Using the Adobe PostScript driver for Windows 3.1

To select printing options, follow these steps:

1. From the **Control Panel**, double-click **Printers**.
2. In the **Printers** dialog box, select the **Tektronix Phaser 300X** printer, then click **Setup**. A dialog box appears with the printer's name across the top.
3. Click the following tabs to see printing options; refer to your Windows documentation for more information on tabs and options.
 - Click the **Paper** tab to see media options, such as media sizes and media types.
 - Click the **Features** tab to see printer-specific options, such as color corrections.
 - Set the **Timeout settings**.

Not Selected: Type a value of **0**, or between **15** and **999**, in this text box to change the number of seconds Windows waits before notifying you that a printer is off-line. The default is **15** seconds.

Transmission Retry: On large or multiple-page documents you may see an Alert message that the printer is no longer accepting data before the job is completely sent to the printer. When using a shared printer, you should set this option to a larger value, such as **900 seconds** (15 minutes) to avoid these unnecessary timeouts. Type a value between **45** and **999** in this text box; the default setting is **45** seconds.

- Click the **PostScript** tab to see PostScript-related options.
 - In the **Performance Options** field, select the **Use PostScript Level 2 Features** option.
- Click the **Job Control** tab to see print job-related options.
 - The PostScript header contains important PostScript information that must accompany each print job; it is not a banner page printed with each job. If an option is not selected, an error message is displayed on your computer screen and your job does not print. Click one of the following in the **PostScript Header** field:

Select **Download Each Job**. This option downloads PostScript header information with each print job.

Select the **Already Downloaded** option to save the PostScript header information in the printer, then click the **Download** button. This option makes print files a little smaller and faster than the first option, but you need to click the **Download** button every time the printer is turned off or reset.

- For better performance, select the **Binary Mode** option.

Using the Windows NT PostScript driver

If you are using Microsoft Windows NT, follow the instructions in the *Phaser 300X Drivers and Utilities Printing Reference* to set up a Windows NT PostScript driver with a Phaser 300X printer. You can select printer page sizes in the driver for Windows NT applications, however, TekColor color corrections and other PostScript Level 2 features are not supported by the Windows NT driver. Refer to page 7-5 for instructions on selecting color corrections from the printer's rear panel switches. Refer to your Microsoft Windows NT documentation for details on features in the Windows NT driver.

Printing from DOS

Refer to the *Phaser 300X Drivers and Utilities Printing Reference* for information on printing from DOS.

Printing from a Macintosh

To print from a Macintosh, you need a printer driver. Installing one of the supported drivers allows you to select printing features right from your computer. Without a supported driver, you can make some printing selections using the printer's rear panel switches.

Using Macintosh printer drivers

To select printer-specific features, print from one of the following provided drivers. Refer to page 3-12 for the Macintosh "Print features quick reference" table for a list of the printing features and how to find them quickly in each of these drivers.

Phaser 300X driver	see page 3-14
Adobe PSPrinter driver	see page 3-14
Phaser 300X GX	see page 3-15

Using the printer's rear panel switches

Refer to "Rear panel switches" on page 7-5 for instructions on changing the color correction mode with the rear panel switches. Refer to the *Phaser 300X Drivers and Utilities Printing Reference* for detailed information on using the rear panel switches to change other print features.

3 Printing

Print features quick reference: Macintosh printer drivers

Feature	Feature description	Phaser 300X driver	Adobe PS Printer driver	Phaser 300X GX driver
Print-quality modes <ul style="list-style-type: none"> ■ Standard ■ Enhanced ■ Premium 	See page 3-21	Print <ul style="list-style-type: none"> ↳ TekColor button ↳ TekColor Options ↳ Print Quality 	Print <ul style="list-style-type: none"> ↳ Options button ↳ Print Options ↳ Print Quality 	Printing <ul style="list-style-type: none"> ↳ Printer Driver Defaults ↳ Print Quality
Color correction <ul style="list-style-type: none"> ■ Vivid Color ■ None ■ Simulate Display ■ SWOP Press ■ Euroscale Press ■ Commercial Press ■ SNAP Press ■ Monochrome ■ Use Printer Settings ■ Custom Profile*† 	See page 3-22	Print <ul style="list-style-type: none"> ↳ TekColor button ↳ TekColor Options ↳ Color Correction 	Print <ul style="list-style-type: none"> ↳ Options button ↳ Print Options ↳ Color Correction 	Printing <ul style="list-style-type: none"> ↳ Printer Driver Defaults ↳ Color Correction
Media size <ul style="list-style-type: none"> ■ Letter ■ Legal ■ Tabloid ■ Letter Extra ■ Tabloid Extra ■ A4 ■ A3 ■ 4x6 Card ■ 5x7 Card ■ A5 ■ A6 ■ ISOB4 ■ ISOB5 ■ ISOB6 ■ Compliment Slip ■ #10 Envelope ■ C6 Envelope ■ DL Envelope ■ A4 Envelope ■ .5 A4 Envelope 	See page 3-25	Page Setup <ul style="list-style-type: none"> ↳ Paper 	Page Setup <ul style="list-style-type: none"> ↳ Paper 	Page Setup <ul style="list-style-type: none"> ↳ Paper Type

* These features are available with the printer's Extended Features option only.

† Selecting Custom Profile displays another list showing the profiles that you created in PhaserMatch.

Print features quick reference: Macintosh printer drivers (cont'd.)

Feature	Feature description	Phaser 300X driver	Adobe PSPrinter driver	Phaser 300X GX driver
Media source <ul style="list-style-type: none"> ■ Media Tray ■ Manual Feed 	See page 3-32	Print ↳ Paper Source	Print ↳ Paper Source	Print ↳ Paper Feed
Finepoint Sharpening <ul style="list-style-type: none"> ■ On ■ Off 	See page 3-21.	Print ↳ TekColor button ↳ TekColor Options ↳ Finpoint Sharpening	Print ↳ Options button ↳ Print Options ↳ Finpoint Sharpening	Printing ↳ Printer Driver Defaults ↳ Finpoint Sharpening
Color Control Strip <ul style="list-style-type: none"> ■ On ■ Off 	Refer to the <i>Phaser 300X Drivers and Utilities Printing Reference</i> .	Print ↳ TekColor button ↳ TekColor Options ↳ Color Control Strip	Print ↳ Options button ↳ Print Options ↳ Color Control Strip	Printing ↳ Printer Driver Defaults ↳ Color Control Strip

* These features are available with the printer's Extended Features option only.

† Selecting Custom Profile displays another list showing the profiles that you created in PhaserMatch.

Using the Phaser 300X driver

- From the **File** menu, open the **Page Setup** dialog box. Use the **Paper** pop-up menu to select the printer's supported paper sizes.
- From the **File** menu, open the **Print** dialog box. Select media options and paper trays in the **Paper Source** field.
- Click the **TekColor** button in the **Print** dialog box to see the **TekColor Options** dialog box. Select printer-specific options as desired.

Using the Adobe PSPrinter Driver

Note *Refer to the on-line user guide on the printer's CD-ROM for more information on using the Adobe PSPrinter driver.*

- From the **File** menu, open the **Page Setup** dialog box. Use the **Paper** pop-up menu to select the printer's supported paper sizes.
- From the **File** menu, open the **Print** dialog box. Select media options and paper trays in the **Paper Source** field.
- In the **Print** dialog box, click the **Options** button to see the **Print Options** dialog box. There are printer-specific features listed at the bottom of the dialog box.

Using the Phaser 300X GX driver

Printing with a desktop printer

- If you are using QuickDraw GX applications, do *one* of the following:
 - Select any desktop printer in the **Print** dialog box.
 - Drag a document onto a desktop printer icon. The application corresponding to the document opens, prints the document, and then quits.
- If you are using non-QuickDraw GX applications, do *one* of the following:
 - Print to the *default* desktop printer with the **Print** command from the **File** menu.
 - Drag a document onto a desktop printer icon. The application corresponding to the document opens, displays the **Print** dialog box, and waits for you to click **Print**. After printing the document, the application quits.

Selecting printing options

Most of the commands in the **Printing** menu are standard QuickDraw GX driver commands, and are documented by Apple (see the *Macintosh Guide* on-line document for details). The last group of commands in this menu are printer-specific.

Use the **Printer Driver Defaults** command in the **Printing** menu to set default options for the selected desktop printer.

Note *The printer defaults dialog box is also available through the **Print** command in the **File** menu for QuickDraw GX applications.*

Printing from a workstation

Overview

You can print from a UNIX or VMS workstation through Ethernet, Token Ring, parallel, or serial interfaces. Workstation users can print from any application that generates color PostScript.

Note *If you are printing ASCII files directly to the printer, you will need PCL5 activated on your printer; refer to the **Phaser 300X Drivers and Utilities Printing Reference** for instructions.*

To use the TekColor color corrections and other printer features, use one of the following methods:

- PhaserPrint™ software for UNIX workstations functions like a printer driver for selecting printing options, and provides fast screen copy printing (see page 3-17).
- PhaserSym™ software and EasyCopy/X for VMS workstations provides proper communication with the printer.
- The switches on the printer's rear panel let you select printing options; refer to Chapter 7 for instructions on using the rear panel switches.
- Downloadable utility files let you select printing options; refer to the *Phaser 300X Drivers and Utilities Printing Reference* for instructions.

UNIX workstations

For UNIX environments, Tektronix offers the optional PhaserPrint™ software. PhaserPrint software offers driver-selectable printer options and provides fast, raster file and screen copy printing to Tektronix color printers.

The printer's CD-ROM contains a demonstration copy of PhaserPrint software and an on-line instruction guide in the *UNIXDEMO* directory. If you would like to purchase a licensed version of PhaserPrint software, contact your dealer, local Tektronix office, or in the United States, call **1-800-835-6100**.

PhaserPrint software supports for these workstations:

Workstation	Operating System
Sun	SunOS 4.1.3, Solaris 2.3, 2.4
SGI	IRIX 4.0, 5.2, 5.3
HP 9000 700/800	HPUX 9.05
IBM RS/6000	AIX 3.2
DECstation	Ultrix 4.0, 4.4
DEC Alpha	OSF/1 1.3, 3.0

PhaserPrint software works with the workstation's native spooling system to print PostScript files and raster files in these formats: Sun Raster Format (SRF), **xwd**, SGI RGB, and many others.

VMS workstations

To print from VMS workstations, the optional PhaserSym™ utility, a VMS print symbiont, functions as a driver for selecting printing options, and as a queue manager. PhaserSym software is compatible with DEC workstations running VAX/VMS version 5.0 and later. PhaserSym software communicates over the printer's optional TCP/IP Ethernet interface, and is required for proper communication with the printer.

The optional EasyCopy/X software provides fast raster image printing to Tektronix printers.

For more information

- **World Wide Web:** If you have access to the Internet, you can view selected topics on the Phaser 300X printer's web page. Access the printer's documentation from this web address:

`http://www.tek.com/Color_Printers/userdoc/introduction.html`

- **HAL:** Request a document catalog from HAL or EuroHAL, Tektronix' automated fax systems. Refer to "Using the automated fax systems" on page 6-2 for instructions on using HAL and EuroHAL.

Printing from specific applications

For printing from most applications, follow the instructions in the *Phaser 300X Drivers and Utilities Printing Reference* to install drivers and printer software. Refer to the following application notes for details on a few applications with special requirements.

General hints and tips

For hints and tips on printing from a specific application, you can get information in the following places:

- **World Wide Web:** If you have access to the Internet, you can view selected topics on the Phaser 300X printer's web page. Access the printer's documentation from this web address:
`http://www.tek.com/Color_Printers/userdoc/introduction.html`
- **HAL:** Request a document catalog from HAL or EuroHAL, Tektronix' automated fax systems. Refer to "Using the automated fax systems" on page 6-2 for instructions on using HAL and EuroHAL.

Windows applications

Aldus PageMaker and FreeHand

Adobe PageMaker

Macromedia FreeHand

QuarkXPress

Some applications use PostScript printer description files (PPDs) to get information about a printer. Refer to the *Phaser 300X Drivers and Utilities Printing Reference* for instructions on installing the printer's software.

Pantone

If you are using an application that produces PANTONE Colors, see the *Phaser 300X Drivers and Utilities Printing Reference* for information on color library files available for specific applications.

Macintosh applications

QuarkXPress

To use the printer with QuarkXPress, use the installer application on the printer's CD-ROM or diskettes to install the *Phaser 300X.PDF* printer description file. The file is installed automatically with Easy Install. Refer to the *Phaser 300X Drivers and Utilities Printing Reference* for instructions on installing the printer's software. Once the file is installed, the printer's name appears alphabetically in the list of installed printers in the QuarkXPress custom **Page Setup** dialog box.

Adobe Photoshop

The PhaserPrint™ software plug-in operates within the Photoshop application to improve the image data transfer time from your Macintosh to your printer. Use the installer application on the printer's CD-ROM or diskettes to install the PhaserPrint software plug-in. The file is installed automatically with Easy Install. Refer to the *Phaser 300X Drivers and Utilities Printing Reference* for instructions on installing the printer's software. Once the file is installed, select **PhaserPrint** from the **Export** pop-up menu in the **File** menu, and make printing selections. Refer to the *Phaser 300X Drivers and Utilities Printing Reference* for details on using the PhaserPrint software plug-in.

Pantone

If you are using an application that produces PANTONE Colors, see the *Phaser 300X Drivers and Utilities Printing Reference* for information on color library files available for specific applications

Other applications

To use the printer with Aldus PageMaker or FreeHand, and other applications, use the installer application on the printer's CD-ROM or diskettes to install the *PPD* printer description files. Refer to the *Phaser 300X Drivers and Utilities Printing Reference* for instructions on installing the printer's software. Once the files are installed, you can use them to set up a PPD-driven printer driver, such as the Adobe PSpriinter, for your printer; see the *Phaser 300X Drivers and Utilities Printing Reference* for instructions.

Selecting print features

Print modes

The printer has three print-quality modes. In addition to the print-quality modes, you can customize your prints using the TekColor color corrections and Finepoint Sharpening. Refer to the *Phaser 300X Drivers and Utilities Printing Reference* for details on selecting the print quality modes and color correction.

Print-quality modes

Standard The default setting. This is the fastest mode for full color printing. This selection takes about 1 minute to print on A- or A4-size paper (American Letter or Metric Letter), depending on the size and complexity of the image.

Enhanced This mode takes about 2 minutes to print on A-size paper and smoothes banding in solid colors.

Premium This mode produces the smoothest solid color shades. It takes about 4 minutes to print on A-size paper.

Finepoint Sharpening

Finepoint Sharpening, available with 14 Mbytes of memory, uses a special halftoning technique to produce sharper images with crisp edges and smooth color detail. It provides sharpening and higher detail rendering for non-rotated, rectangular scanned image or bitmapped data only.

There are two ways of selecting Finepoint Sharpening:

- Through a printer driver — check the Finepoint Sharpening box *on*.
- By downloading the PostScript utility file. Refer to the *Phaser 300X Drivers and Utilities Printing Reference* for details on downloading utility files.

Color correction

The printer provides TekColor Dynamic Correction, which consists of these color correction modes (Vivid Color, Simulate Display, SWOP, Euroscale, Commercial, SNAP, and Use Printer Settings). You can select these modes in one of these ways:

- **Using a printer driver or a utility file.**

For details on making color corrections through a printer driver or a utility file, refer to the *Phaser 300X Drivers and Utilities Printing Reference*.

- **Using the PhaserMatch application (requires Extended Features option).**

If you have created custom profiles with the PhaserMatch application, selecting PhaserMatch from the list of color corrections generates a list of the custom profiles from which to choose. Refer to the *PhaserMatch User Manual* for details.

- **Using the color correction switches on the printer's rear panel.**

The Phaser 300X allows you to make color corrections with rear panel Switches 8 and 9. Make sure that you have selected **Use Printer Setting** in the driver. The combinations of these two switches have the following effect:

Switch 8	Switch 9	Color correction mode
Down	Down	No color correction
Down	Up	SWOP Press (closely matches a web offset press)
Up	Down	Vivid Color
Up	Up	Use NVRAM setting (default setting is Euroscale Press)

Note *If your printer is on a network and you have changed rear panel Switches 8 or 9, make sure you tell other users on the network since the switches affect **all** prints made with the **Use Printer Setting** option in the drivers. The NVRAM setting can be changed when both switches are **up**, by sending one of the utility files from the CD-ROM.*

Using the rear panel switches for color correction is only necessary if you are not set up to use the Phaser 300X drivers. If you are using TekColor Dynamic Correction in the Phaser 300X drivers, the settings you choose in the driver override the rear panel switches for prints you make from the driver.

For complete information on color correction, refer to the *Phaser 300X Drivers and Utilities Printing Reference*.

- **Using color sampler charts provided on the Phaser 300X CD-ROM and diskettes.**

The Phaser 300X CD-ROM and diskettes contain color sampler charts for CMYK (cyan, magenta, yellow, and black), RGB (red, green, and blue), HSB (hue, saturation, and brightness), and PANTONE Colors. The charts consist of colored rectangles and coordinate values. Print out the appropriate chart for your application, and use the coordinate values to select colors within an application. For example, your printer can produce PANTONE-approved process color simulations. Use the PANTONE Color sampler chart to select the process color values within software applications that best simulate PANTONE Colors on the Phaser 300X.

For details on printing the charts, refer to the *Phaser 300X Drivers and Utilities Printing Reference*.

Color Control Strip feature

The printer software also includes the Color Control Strip feature, which allows you to check the consistency of printed colors between prints made on the same printer, as well as between prints made on more than one of the same type or model of printer. When this option is selected in the printer driver, the printed page includes a band of colors along the bottom edge; the colors in this band reflect the currently selected color correction. For more information, refer to the *Phaser 300X Drivers and Utilities Printing Reference*.

All about media

The printer prints on a variety of paper sizes and grades. The size and grade of paper you select depends on your printing needs and whether you are using the paper tray or manually feeding the paper into the printer. For information on ordering paper, refer to the supplies information sheet.

You can recycle the printed paper the same way you would recycle paper from any laser printer.

Grade and finish

You can use a variety of paper grades with this printer, including Bond, Book, Cover, Index, Tag, Text, and Offset.

Note *The terms this manual uses (such as Book, Bond, and Cover) to describe paper grades the printer uses, may differ from the terms your country uses. Refer to the table “Guidelines for paper grade, weight, and thickness” on page 3-26 for the metric equivalent of paper grades.*

The best papers to use with this printer are paper grades such as Bond, Book, and Text. You can use Bond papers for newsletters, forms, and reports. Book papers are best for manuals, fliers, and catalogs. And Text papers are best for textbooks, brochures, and color comps.

Finish refers to the smoothness of the paper. The printer can print on matte-finish paper as well as high-gloss paper. The finish affects the durability of the print. Generally, matte finishes produce more durable prints than glossy finishes because the ink bonds to porous surfaces better.

Avoid using “fuzzy” papers that have loose fibers. If you use extra-fibrous papers, you may have to clean the printer more frequently. Also, avoid watermarked papers because the watermark may be visible in the finished print.

If you want to learn more about paper grades and finishes, refer to *Pocket Pal: A Graphic Arts Production Handbook*, published by International Paper Company.

Size

The Phaser 300X prints on paper that ranges in size from 100 x 150 mm to 305 x 457 mm (4 x 6 in. to 12 x 18 in.). The following table shows which paper sizes fit into the paper trays. Use manual feed when you want to print on paper that is smaller than A-size or A4-size.

To print the largest image possible on Tabloid Extra (12 x 18 in.) paper, the printer must have at least 14 Mbytes of memory. Refer to “Margins and image area” on page 28 for details on the print area and paper size.

Paper size and input method

Input method	Size	Dimensions	Thickness (per sheet)
Universal tray	A (American Letter)	8.5 x 11 in.	About .08 to .25 mm (.003 to .01 in.)
	Legal	8.5 x 14 in.	
	B (American Tabloid)	11 x 17 in.	
	Tabloid Extra	305 x 457 mm 12 x 18 in.	
	A4 (Metric Letter)	210 x 297 mm	
	A3 (Metric Tabloid)	297 x 420 mm	
Letter paper tray	A (American Letter)	8.5 x 11 in.	
	A4 (Metric Letter)	210 x 297 mm	
Manual feed	From postcard to Tabloid Extra	From 100 x 150 mm (4 x 6 in.) to 305 x 457 mm (12 x 18 in.)	

Weight and thickness

The following table presents guidelines you should follow when selecting the grade, weight, and thickness of paper to use with the printer. The paper must have enough thickness or stiffness to feed through the printer properly. Manual feed accepts a wider range of grades and weights than the paper trays.

Avoid papers that are extra stiff or extremely thin. Papers that are extremely thin may not feed properly. Also, do not use papers that have a basis weight higher than 220 g/m² (equivalent to 80-pound Cover) or papers that are thicker than 0.254 mm (0.01 in.).

Guidelines for paper grade, weight, and thickness

Input method	Grade	Weight (per ream of 500 sheets)	Metric equivalent basis weight	Thickness (per sheet)
Paper tray	Bond	16 to 40 lb.	61 to 158 g/m ²	About .08 to .25 mm (.003 to .01 in.)
	Book and Text	40 to 120 lb.	59 to 178 g/m ²	
	Cover	50 lb.	135g/m ²	
Manual feed	Bond	13 to 40 lb.	49 to 158 g/m ²	
	Book and Text	30 to 120 lb.	44 to 178 g/m ²	
	Cover	50 to 80 lb.	135 to 216 g/m ²	
	Bristol	67 to 80 lb.	148 to 178 g/m ²	
	Index	90 - 110 lb.	163 - 203 g/m ²	
	Tag	100 - 120 lb.	163 - 203 g/m ²	

Grain

Grain refers to the position of fibers in the paper. The fibers run the length (long grain) of the paper or the width (short grain). For the best printing results, load the paper in the direction of the grain. If you load the paper across the grain, the edges of the paper may wrinkle. Some paper manufacturers identify the grain on the paper's package label.

When you use A-size or A4-size paper, the paper should be short-grained. You can purchase short-grained A-size and A4-size paper from Tektronix.

1. Long grain
2. Short grain
3. An example of how to load short-grained A-size or A4-size paper in the standard or universal paper trays.

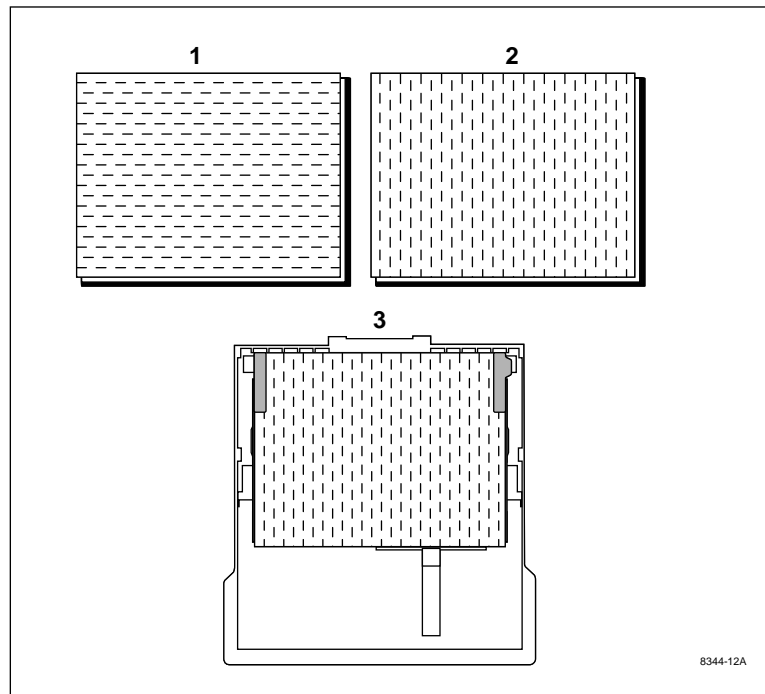

Margins and image area

The image area is the part of the paper where the image appears. When the printer places an image on the paper, the image area is a bit smaller than the actual paper size. You may need to adjust the page margins in your application software to match the image area. The printer must be set for either American- or Metric-size media (set the rear panel switch, **Switch 6**, *up* for metric and *down* for American).

The difference between the image area and the paper size for the top margin (side of the paper that enters the printer first) and the side margins are 5 mm (0.2 in.). The bottom margin (side of the paper that enters the printer last) is about 6.3 mm (0.25 in.). The following illustration shows the top, bottom, and side margins.

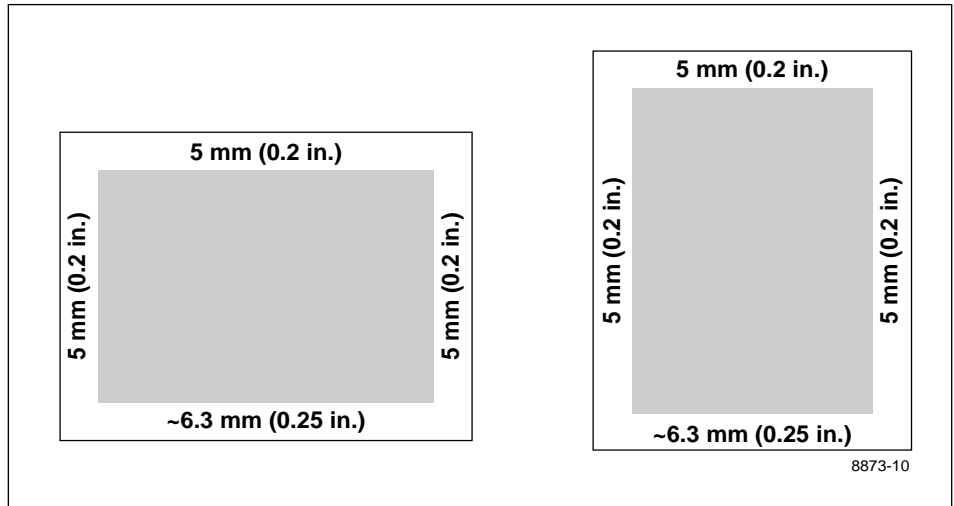

Image area for Tabloid Extra

The standard printer configuration has 10 Mbytes of memory. With 10 Mbytes of memory, the image area for Tabloid Extra (305 x 457 mm or 12 x 18 in.) media is 264 x 413 mm or 10.6 x 16.5 in.

When you add 4 Mbytes of memory to the printer, the image area for Tabloid Extra media increases to 297 x 445 mm or 11.7 x 17.5 in.

Image area for color prints

For A- and A4-size paper, the image area depends on how you load the paper into the printer. The side margins are always 5.0 mm (0.2 in.).

Print Area

Paper size	Print area
A 8.5 x 11 in. (long side of the paper enters the printer first)	8.02 x 10.58 in.
A 8.5 x 11 in. (short side of the paper enters the printer first)	8.08 x 10.52 in.
A4 210 x 297 mm (long side of the paper enters the printer first)	197.6 x 286.5 mm
A4 210 x 297 mm (short side of the paper enters the printer first)	198.8 x 284.7 mm
Legal 8.5 x 14 in.	8.08 x 13.52 in.
B (American Tabloid) 11 x 17 in.	10.58 x 16.52 in.
A3 (Metric Tabloid) 297 x 420 mm	286.5 x 407.9 mm
Tabloid Extra 12 x 18 in. 304.8 x 457.2 mm	11.7 x 17.52 in. 297.1 x 445.0 mm

Image orientation

Orientation refers to how the image appears on the print. You specify the image orientation through your software application or printer driver. The size of paper you use and how you feed it into the printer do not affect the image orientation.

1. Portrait
2. Landscape

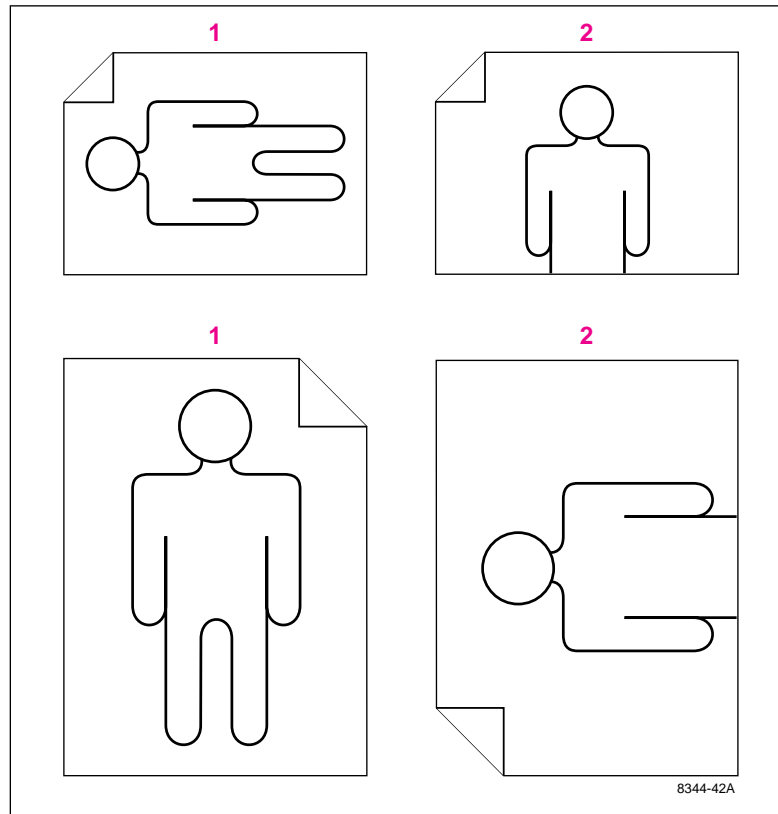

Note *If you are manually feeding media, make sure that the media tray is installed and loaded with the same size paper, in the same orientation, that you are using for manual feed. To avoid clipping, make sure that both paper guides in the media tray (length and width) are touching the edge of the media.*

Media handling

- Clean the paper tray and the tray's cover. Dust and dirt in the paper tray can be transferred to the paper, resulting in poor print quality.
- Handle transparencies by the edges and with both hands to avoid fingerprints and creases, which can result in poor print quality.
- To avoid having the paper stick together, gently fan the paper before loading it into the paper tray.

Using the paper trays

Use the paper tray for standard-sized paper and for paper grades such as Book, Bond, Text, and 50-lb. Cover. Refer to the table on page 3-25 for a complete list of paper sizes that the trays accommodate.

For the best printing results and the fastest print time, load short grain A- and A4-size paper into the paper trays so that the long side of the paper enters the printer first as shown in illustrations 1 and 3.

1. A/A4-size paper tray (optional)
2. Universal paper tray (standard)
3. Universal paper tray (standard)

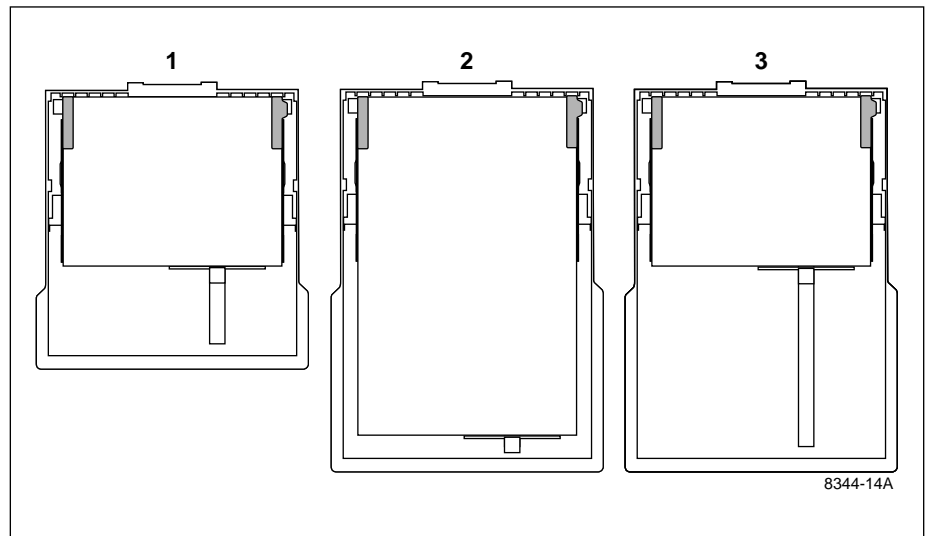

Loading letterhead

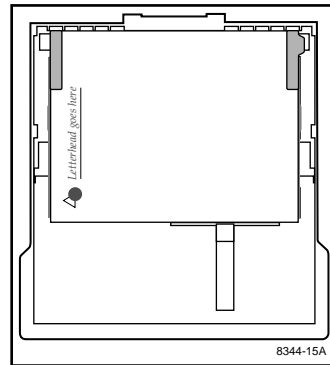

Loading three-holed paper

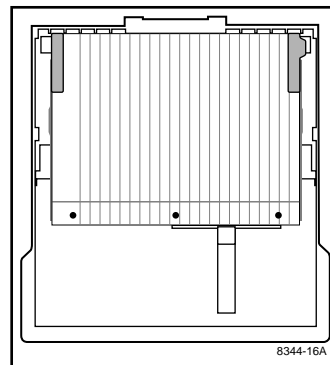

Caution When using three-holed paper, make sure that the printed image does not cover the holes in the paper. If the image overlaps the holes, ink gets on the drum, which, if it is not immediately cleaned off, can affect the quality of your prints and cause **Internal Jam** errors. Make sure that no ink is on the drum, especially on the center of the drum.

Using manual feed

Use manual feed for thick paper such as Cover, envelopes, and paper sizes that range from 100 x 150 mm (4 x 6 in.) to 305 x 457 mm (12 x 18 in.).

Note *All page sizes except A-size (8.5 x 11 in.) and A4-size (210 x 297 mm) must be fed into the printer so that the short side of the paper enters the printer first. If you have not selected manual feed in the driver window, manual-fed A- and A4-size paper must be fed into the printer in the same orientation as the current media that is loaded in the paper tray.*

Inserting the paper

1. Adjust the guides to the width of the paper, depending on the desired orientation.

A-size (8.5 x 11 in.) or A4-size (210 x 297 mm) paper must be fed into the printer so that its orientation matches the orientation of the current media loaded in the paper tray.

2. Insert the paper until it stops.
3. Wait 5 seconds after the first sheet enters the printer before inserting a second sheet.

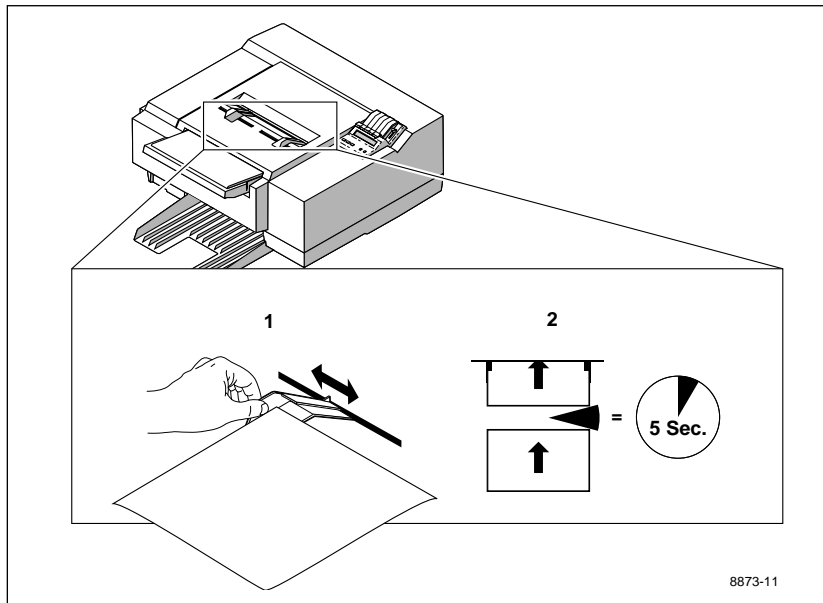

Manual feed examples: paper, envelopes

Note *If you have not selected manual feed in the driver, A-size (8.5 x 11 in.) or A4-size (212.5 x 275 mm) paper must be fed into the printer in the same orientation as when it is picked from the paper tray.*

1. A-size (8.5 x 11 in.) and A4-size (210 x 297 mm).
2. Legal-size (8.5 x 14 in.), Tabloid size (11 x 17), A3-size (297 x 420 mm), and other large paper.
3. Small paper, such as 100 x 150 mm (4 x 6 in.). Be sure to insert the narrow end of the paper first.
4. Envelopes with the flap open and to the right.

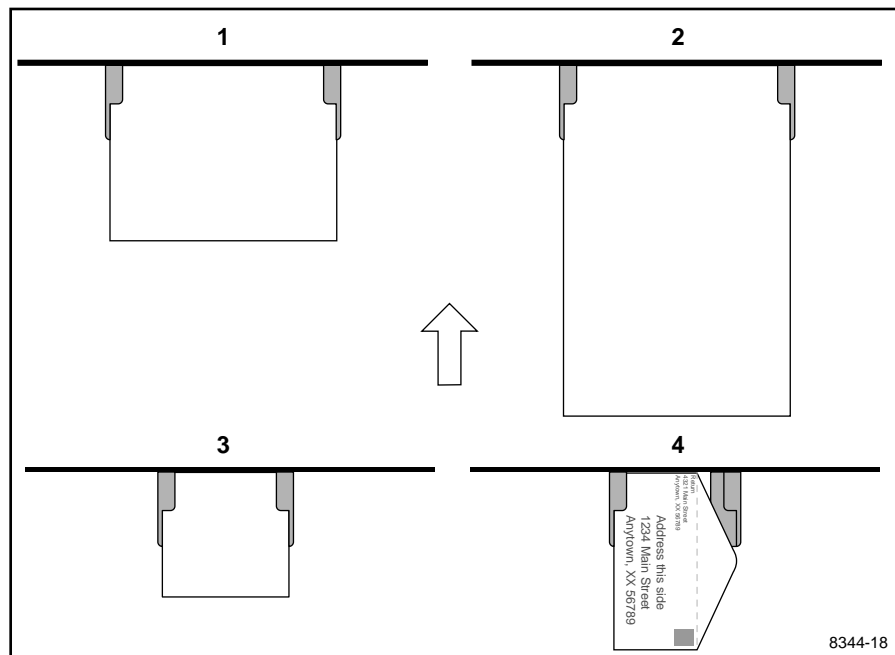

Making transparencies

Follow these guidelines when you make transparencies:

1. Use only Tektronix transparencies.
2. Load transparencies with the white strip (Tek[®] logo) and blue arrows facing up.
3. **When using the paper tray:** load the transparencies so the white strip (Tek[®] logo) and blue arrows enter the printer first.
4. **When using manual feed:** insert the side with the white strip (Tek[®] logo) and blue arrows into the printer first. Make sure that the paper tray is set up as shown, with the long side of the paper entering the printer first.

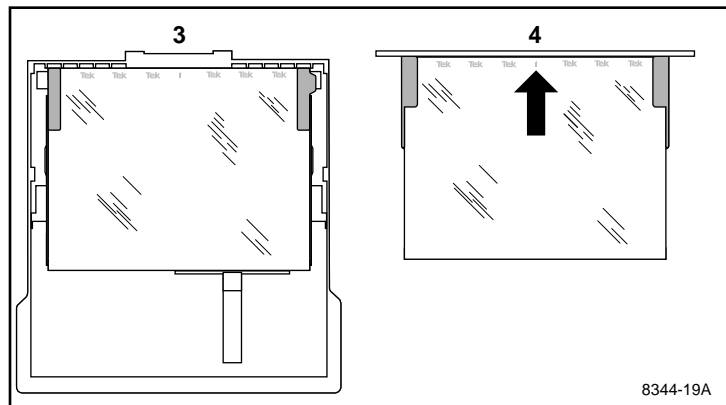

Note Do not re-use transparencies that have been fed through the printer once (for example, after jams or if the transparency is ejected without being printed).

Resident typefaces (PCL5)

For PCL5 (Printer Command Language) printing (HP Laserjet III emulation), the printer supports Courier, Times, and Universe typefaces in medium, bold, italic medium, and italic bold. (PCL5 support is optionally available with the Extended Features option, and must be separately enabled. Refer to the *Phaser 300X Drivers and Utilities Printing Reference* for details.)

Downloading Macintosh and TrueType fonts

The fonts resident in the Phaser 300X printer are stored in the printer as outlines and are always available for printing. The PostScript interpreter in the printer can also accept and store additional fonts known as downloadable fonts. If you want to print PostScript outline fonts that are not built into the printer, you can transfer or download outline fonts from your computer to the printer. Downloading fonts saves print time if you plan to print several documents or a large document using those fonts.

When you download a font, it is stored in the printer's memory or on a SCSI hard disk attached to the printer. You can download as many outline fonts as the printer's memory or hard disk allow.

The printer accepts Type 1 and Type 3 downloadable fonts including those from Adobe, Agfa, Bitstream, Microsoft, Apple, and many others.

The Phaser 300X Color Printer also accepts TrueType downloadable fonts which can be scaled to any point size. TrueType fonts look the same on the screen as they do when printed.

You download a font from a PC or Macintosh the same way you download fonts to any PostScript printer. Follow the documentation that was shipped with your fonts.

If you have an external hard disk connected to the printer, you can store the downloadable fonts on it.

Installing Macintosh screen fonts

The Phaser 300X CD-ROM and diskettes include these typeface families: Times, Helvetica, Courier, Symbol, Helvetica Narrow, Helvetica Condensed, Palatino, ITC Avant Garde Gothic, ITC Bookman, ITC Zapf Chancery, ITC Zapf Dingbats, and New Century Schoolbook.

You must install these screen fonts if you want to see the printer's resident typefaces on the Macintosh screen. These are installed automatically with the Macintosh installer.

Printer languages: PostScript, HP-GL, PCL5

The Phaser 300X supports PostScript Level 1 and Level 2 and HP-GL (Hewlett-Packard Graphics Language) printer languages. Additionally, the printer supports monochrome PCL5 (Printer Command Language) as a separately enabled option. PCL5 requires 22 Mbytes of memory.

The following table shows the default language setting for each port.

Default printer port settings

Port	Language
Serial	PostScript
Parallel	PostScript
LocalTalk	PostScript
EtherTalk	PostScript
LPR	PostScript
AppSocket	Automatic Language Selection
NetWare	Automatic Language Selection

If you want to use an HP-GL application on a PostScript port, you must explicitly set up that printer port for HP-GL data or enable Adobe IntelliSelect™ *automatic language selection*. If you want to use a PCL5 application, you must enable automatic language selection. Refer to the *Phaser 300X Drivers and Utilities Printing Reference*.

If automatic language selection is enabled, you can change back and forth between HP-GL, PostScript, and PCL5 regardless of the default language. You can also change the default language so that the next time you turn on the printer, it expects to receive HP-GL, PostScript, or PCL5 data on a specific port.

The printer has default values for the HP-GL parameters, such as pen color and pen width. However, you can change these values. Refer to “Changing the HP-GL default settings” on page 43 for more information.

Switching printer languages

The Phaser 300X printer can be set to automatically sense the language of the print job and process it accordingly. This Adobe IntelliSelect™ *automatic language selection* feature allows you to send jobs to the printer in different languages. With automatic language selection enabled, you can automatically switch between all three languages: PostScript, HP-GL, and PCL5. You can also set up any printer port to receive one language only. If you set up a port to receive a particular language only, that port will only accept jobs of that type.

To enable or disable automatic language selection on a port, send the appropriate PostScript utility file to the printer. For more information, see the *Phaser 300X Drivers and Utilities Printing Reference*.

Note *This utility file is best used **only** if you plan to switch between all three languages or if you will mostly be using PCL5.*

Printing with PCL5

In PCL5 mode (HP LaserJet III emulation), the printer supports Courier, Times, and Universe typefaces in the following styles and stroke weights: bold medium, italic medium, and bold italic.

To use a PCL5 application, you must customize PCL5 and set up a printer port with the appropriate automatic language selection utility file (refer to the *Phaser 300X Drivers and Utilities Printing Reference* for information about utility files).

Printing with HP-GL

1. Change the printer's language from PostScript to HP-GL. (Refer to the *Phaser 300X Drivers and Utilities Printing Reference* for details on how to change the language.)
2. Set up the printing options in your HP-GL application by selecting a printer driver that supports the HP 7475A plotter.
3. Print from your HP-GL application as usual.

Printing PostScript

Change the printer's language from HP-GL to PostScript. (Refer to the *Phaser 300X Drivers and Utilities Printing Reference* for details on how to change the language.)

Changing the HP-GL default settings

The printer has default values for the HP-GL parameters, such as pen color and pen width. When you turn the printer off and on (or reset it), the HP-GL values return to their default settings.

The printer has the following HP-GL default settings:

- Scales the image to paper size.
- Timeout interval of 15 seconds.
- A pen width of 0.12 millimeters.
- Pen colors for the first eight pens:
 - Pen 1 = black
 - Pen 2 = red
 - Pen 3 = green
 - Pen 4 = blue
 - Pen 5 = cyan
 - Pen 6 = magenta
 - Pen 7 = yellow
 - Pen 8 = orange
- Background color is white, which is pen number 0.

To change the values, use the PostScript **setdevparams** command. For details, refer to the *Phaser 300X Drivers and Utilities Printing Reference*.

Caring for Your Printer

Overview

This chapter describes the following tasks to care for your printer and keep it in peak operating condition:

- **Adding ink**
When the front panel displays the message that tells you to add ink, or when the ink-level icon shows half-full or empty.
- **Changing the fuser wiper**
When you open a new box of black ColorStix ink sticks.
- **Emptying the waste bin**
When the front panel message tells you to empty the bin.
- **Cleaning the printer**
Describes how to clean the drum, paper clamp, paper tension blade, three paper-pick rollers inside the printer, the fuser roller, and the feed rollers.

Adding ink

Warning *The melted ink is hot.*

The Phaser 300X Color Printer is shipped already loaded with ColorStix ink. Add ink when the front panel displays the message that tells you to add ink, or when the **INK LEVEL** icon in the front panel indicates a half-full or empty condition. For example, when you see the following message, add a black ink stick:

Stopped -- Add black

When the **INK LEVEL** is half-full, add one ink stick. When the **INK LEVEL** is empty, you can add two ink sticks; however, load one right after the other (if you delay, the printer will not allow the second ink stick to be loaded for approximately 15 minutes).

Caution *Do not load used ink into the printer. Reusing waste ink ruins the printhead and invalidates the warranty.*

Do not load broken ink sticks; they can cause the ink-loading system to jam.

The ColorStix ink sticks will break if dropped; handle them with care. Keep them in their original containers until you are ready to use them.

1. Open the ink cover.
2. Drop in a ColorStix ink stick. Each ink stick is uniquely shaped to fit into the correct ink-loading bin.
3. Close the ink cover to enable the ink load lever.
4. When prompted, gently pull down the ink load lever and release it.

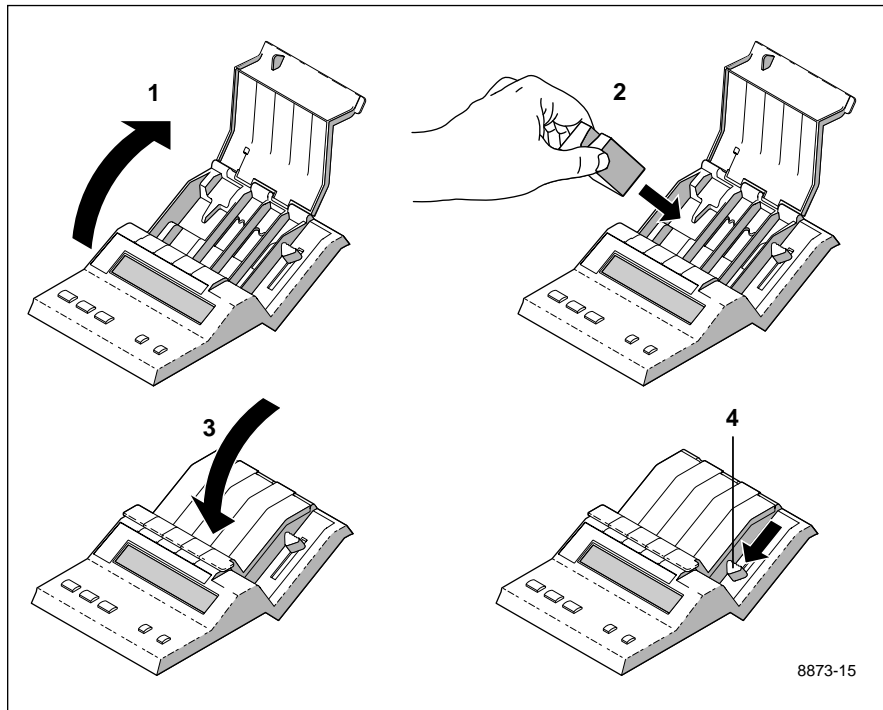

Changing the fuser wiper

Replace the fuser wiper (**A**) when you open a new box of black ColorStix ink sticks or after 2,000 prints, whichever comes first. Each box of black ink sticks contains a new fuser wiper.

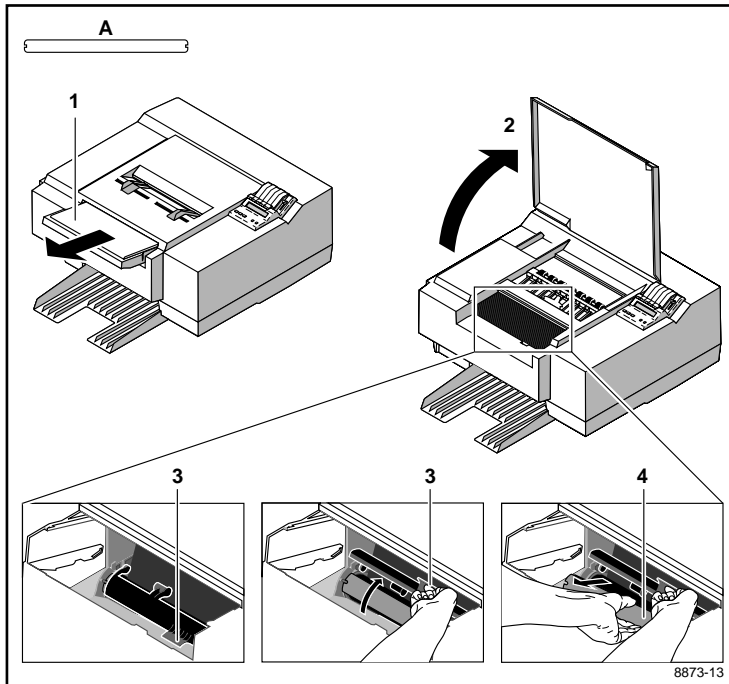

1. Remove the paper tray.
2. Open the printer's top cover.
3. Lift the fuser wiper cover.
4. Pull out the old fuser wiper and insert the new one. As you insert it, line up the notches on the fuser wiper with the notches in the printer.

Note To prevent paper-pick problems, clean the paper-pick and feed rollers when you change the fuser wiper. Refer to "Cleaning the paper-pick rollers" on page 4-11 and "Cleaning the feed rollers" on page 4-12.

Emptying the waste bin

The waste bin remains locked in place until it needs emptying. There are two conditions when you should empty the waste bin:

- When the front panel displays the following message:
`Stopped -- Empty waste bin`
- When you prepare the printer for shipment or move the printer a long distance, in which case you must use the **Utilities** mode. See “Front panel” on page 7-2.

Note *Each time you remove the waste bin, be sure to empty it completely.*

Used ink is nontoxic; it can be treated as normal office waste.

Emptying the waste bin when front panel message displays

Note *The waste bin is locked during normal operation. Do not pull the drawer out unless the front panel message is displayed.*

1. Remove the waste bin by sliding it out. You may have to tug slightly on the waste bin to remove it.
2. Empty the contents of the waste bin by twisting the bin.
3. Replace the waste bin back into the printer.

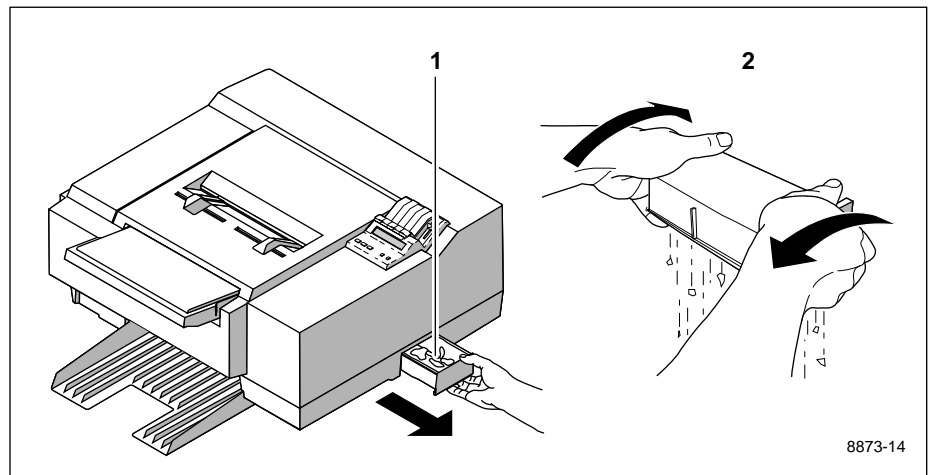

Caution *Do not load used ink into the printer. Reusing waste ink ruins the printhead and invalidates the printer warranty.*

Emptying the waste bin before moving the printer

The printer locks the waste bin in place until it needs emptying. However, you can use the **Utilities** mode to unlock the waste bin so that you can empty it before the front panel message prompts you to do so. See “Utilities mode menu structure” on page 7-4 for detailed information about the **Utilities** mode.

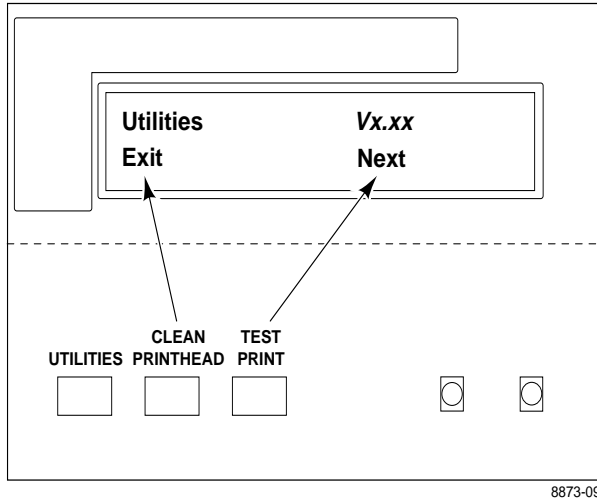

1. When the printer is on and the Ready message appears in the front panel, press the **UTILITIES** button. You see this message (*Vx.xx* is the firmware version number):

```
Utilities    Vx.xx
Exit        Next
```

In the **Utilities** mode, you can scroll through the menu selections using the **TEST PRINT** button (which corresponds to Next in the first menu window), and execute a function or change a setting using the **CLEAN PRINT HEAD** button (which corresponds to Exit in the first menu window).

2. Press the **TEST PRINT** button several times to scroll through the menu selections until you see this message:

```
Waste bin
Unlock    Next
```

3. Press the **CLEAN PRINT HEAD** button to unlock the waste bin.
4. Empty the waste bin, then replace it back into the printer.
5. Press the **TEST PRINT** button until you return to this message.

```
Utilities    Vx.xx
Exit        Next
```

6. Press the **CLEAN PRINT HEAD** button to exit the **Utilities** mode.
7. Wait for Ready to be displayed in the front panel, then turn off the printer. Refer to Appendix C, “Moving Your Printer,” for information on how to prepare the printer for shipment or a long move.

Cleaning the printer

Periodically cleaning the printer can help you avoid various paper-feeding, paper-jamming, and image-quality problems. Use the cleaning kit to clean the drum, the wiper, the paper clamp, the paper tension blade, and the paper-pick rollers inside the printer. You can also use the kit to clean the fuser roller and the feed rollers.

For information on how to identify printing problems and the solutions that involve cleaning, refer to Chapter 6, "Troubleshooting."

New printer cleaning supplies

When you receive your new printer, you receive these cleaning supplies:

1. *Cleaning Instructions* booklet
2. Cleaning tool
3. Lint-free wipes
4. Foam swabs
5. Plastic bottle for dispensing isopropyl alcohol
6. Fuser cleaning pad

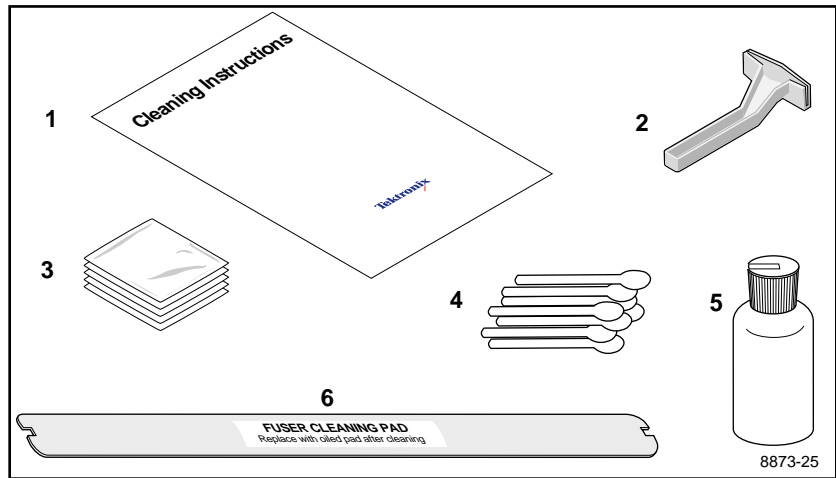

Reorder cleaning kit supplies

To reorder the cleaning kit (Tektronix order number 016-1144-00):

- Order by phone toll-free in the United States: **1-800-835-6100**
- Order by Fax: **(503) 682-2980**
- Order through your local Tektronix dealer.

When you reorder the cleaning kit, you receive these items:

1. *Cleaning Instructions* booklet
2. Cleaning tool
3. Lint-free wipes (isopropyl alcohol-saturated)
4. Fuser cleaning pad
5. Fuser wiper
6. Foam swabs (isopropyl alcohol-saturated)

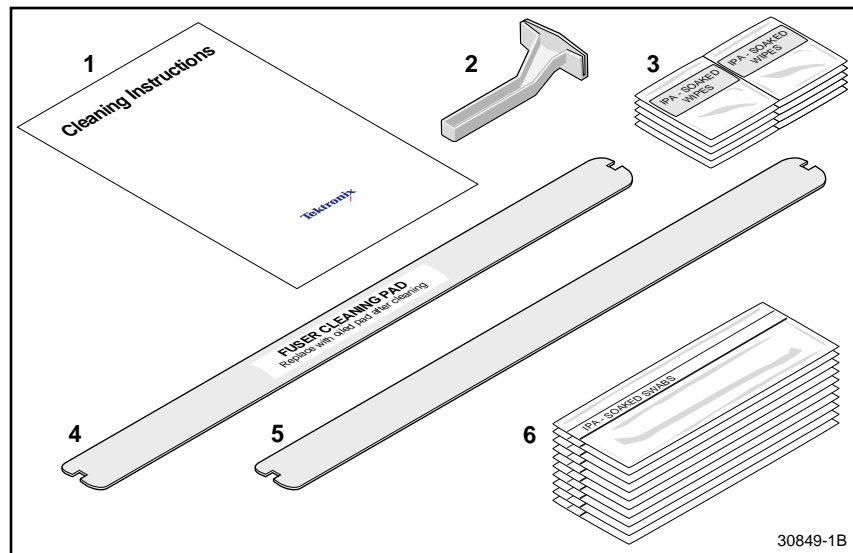

Using isopropyl alcohol

You must supply isopropyl alcohol (available at pharmacies) because shipping regulations prohibit supplying alcohol or presoaked cleaning materials with the printer.

In general, it is best to use the purest isopropyl alcohol (99%) available to you. Alcohol that is 90% pure also works well. You can use 70% pure isopropyl alcohol, but if you do, you must wait much longer after cleaning to ensure that it is completely dry. For example, 99% isopropyl alcohol might dry in as quickly as one minute; 70% isopropyl alcohol can take as long as 15 minutes.

Caution Do not use rubbing alcohol because it can contain oils that leave undesirable residue on the printer parts.

Wherever the cleaning instructions refer to a *lint-free cloth moistened with isopropyl alcohol (A)*, you can substitute a *pre-soaked alcohol cloth (B)*. The reorder cleaning kit (order number 016-1144-00) includes these pre-soaked alcohol cloths. You can also order these packets separately in packs of 10 (order number 006-7824-00).

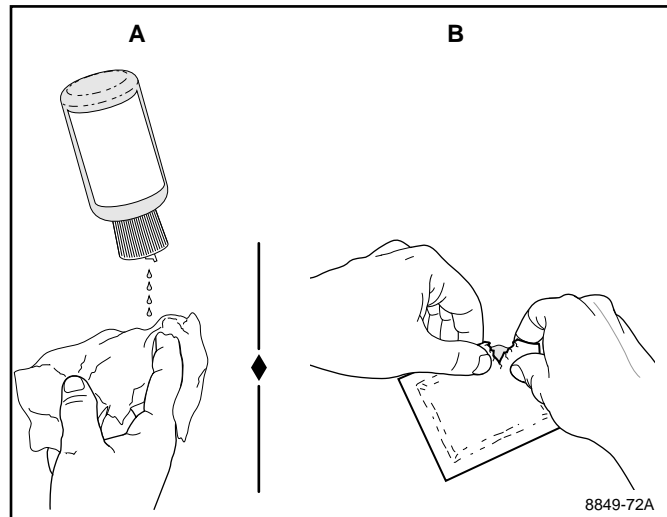

Cleaning the paper-pick rollers

If you have been using coated paper, you may have to clean the paper-pick rollers to avoid paper-pick problems. To prevent paper-pick problems, clean the paper-pick rollers every time you replace the fuser wiper and open a new box of black ink. Use an alcohol-dampened wipe to clean the paper-pick rollers.

1. Remove the paper tray and open the top cover.
2. Place and hold the wipe against the bottom of a roller.
3. Rotate the paper-pick roller three to four times by turning the bar.
4. Repeat Steps 2 and 3 for each roller.

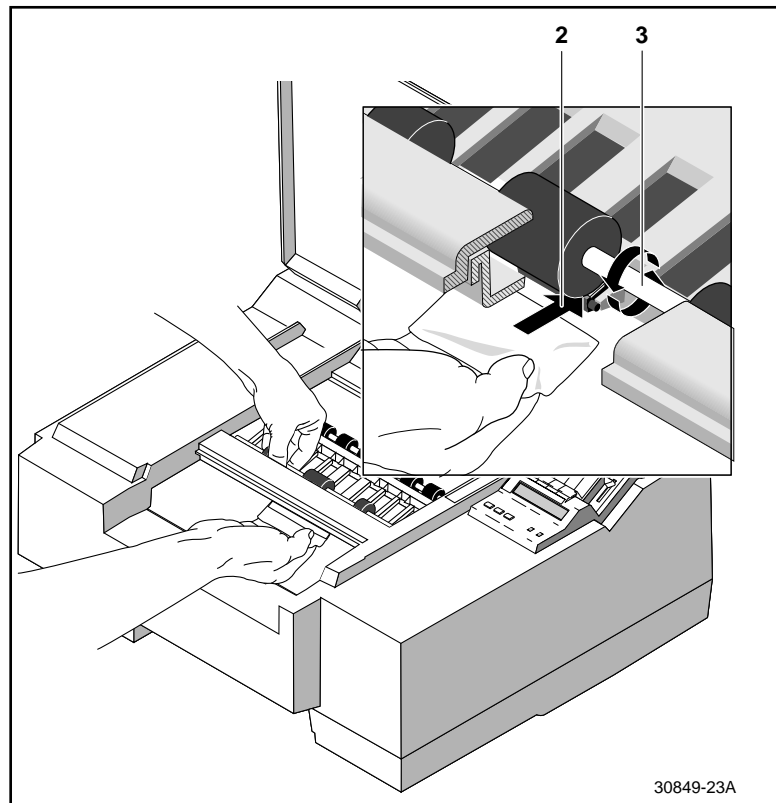

30849-23A

Cleaning the feed rollers

If you have been using coated paper, you may have to clean the feed rollers to avoid paper jams. Use an alcohol-dampened wipe to clean the top and bottom feed rollers.

1. Open the top cover.
2. Place and hold a wipe against each roller. Turn the top roller to clean.

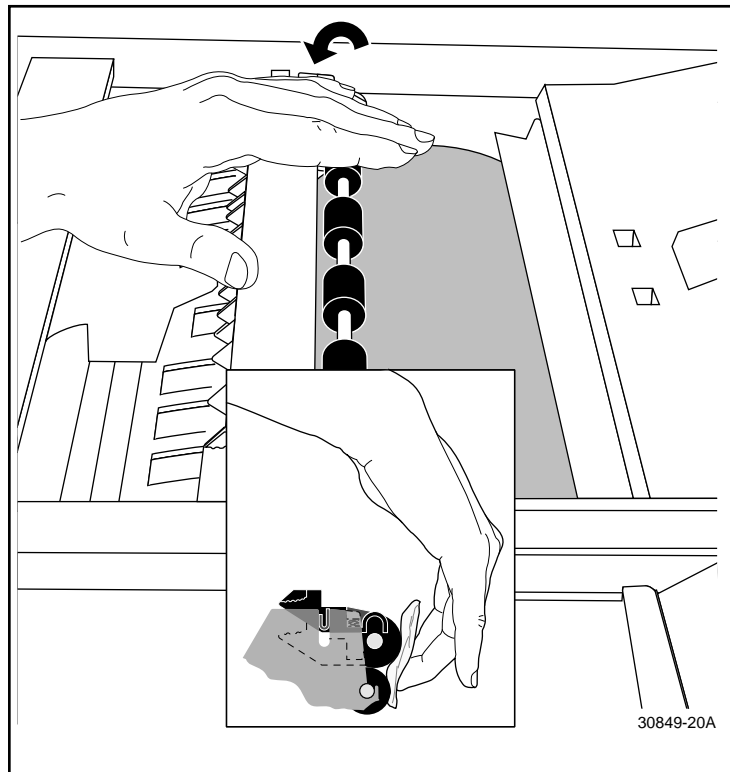

Cleaning the paper tension blade, paper clamp, and drum

If your prints have streaks or spots, clean the paper tension blade, paper clamp, and drum. When you clean the paper tension blade, paper clamp, and drum, the printer must be in **Utilities** mode.

1. When the printer is on and the Ready message appears in the front panel, press the **UTILITIES** button. You see this message (*Vx.xx* is the firmware version number):

```
Utilities    Vx.xx
Exit        Next
```

In the **Utilities** mode, you can scroll through the menu selections using the **TEST PRINT** button (which corresponds to **Next** in the first menu window), and execute a function or change a setting using the **CLEAN PRINT HEAD** button (which corresponds to **Exit** in the first menu window).

2. Press the **TEST PRINT** button several times to reach this message:

```
Cleaning mode
Start      Next
```

3. Press the **CLEAN PRINT HEAD** button to reach this message:

```
Cleaning mode
Open cover to clean
```

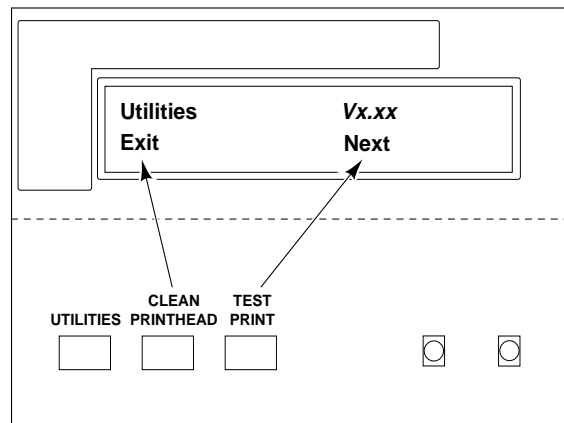

4. Open the top cover. When the top cover is open, this message appears in the front panel:

Cleaning mode
↑ ↓ Clean drum

5. Press the button inside the printer to open the rear cover.

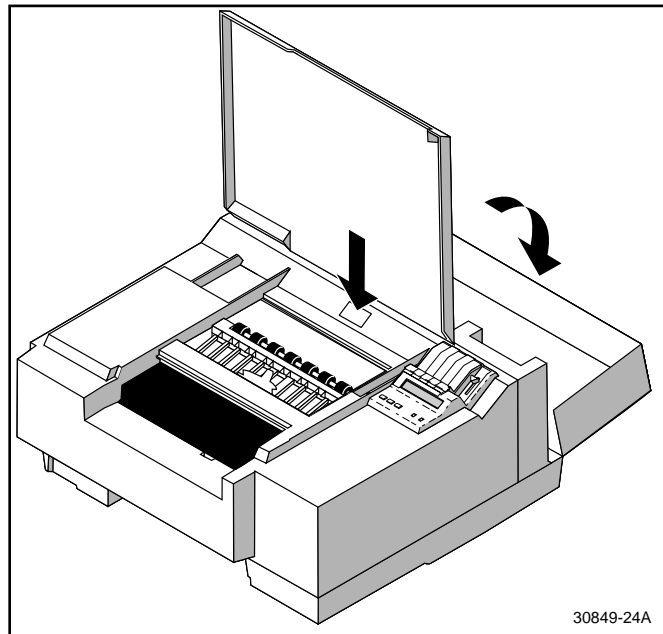

After you open the rear cover, the following message appears in the front panel:

Cleaning mode
Clean blade

When the message appears, the paper tension blade is positioned so that you can clean it.

6. Clean the paper tension blade with the cleaning tool provided:
 - a. Place an alcohol-dampened wipe over the cleaning tool.
 - b. Press the cleaning tool over the edge of the paper tension blade.
 - c. Clean the entire length of the paper tension blade and continue cleaning the blade until you remove the ink. You may have to reposition the wipe as you clean. Although you may not be able to see it, there may be ink on the back of the blade as well as the front. It is very important that you clean the back of the blade thoroughly.

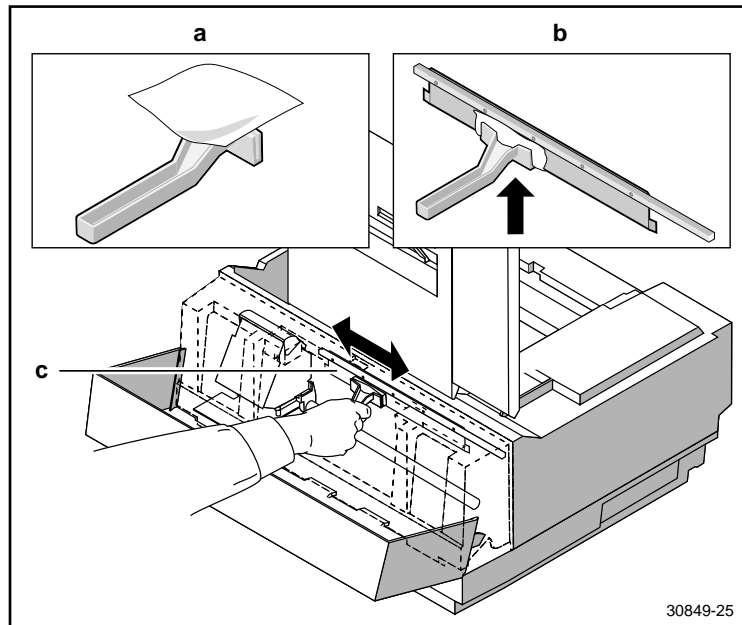

Warning *The printhead is hot. Do not touch it.*

The paper tension blade has a sharp edge; to avoid injury, use the cleaning tool provided when you clean the blade.

7. Close the rear cover so that the following message appears in the front panel:

Cleaning mode
↑ ↓ Clean drum

8. Hold down the **TEST PRINT** button to rotate the drum until the paper clamp appears and opens.
9. Use an alcohol-dampened foam swab to clean the paper clamp. Clean inside and outside the paper clamp.

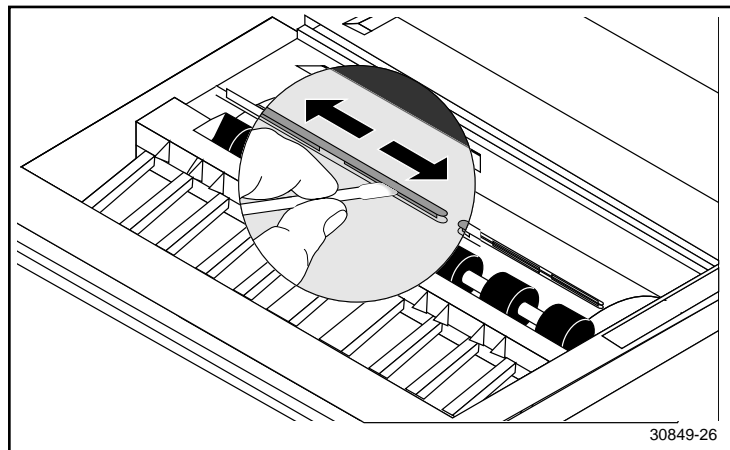

Warning *The paper clamp has sharp edges. To avoid injury, be careful when you clean the paper clamp.*

10. Clean the drum.
 - a. Hold down the **TEST PRINT** button to rotate the drum until the paper clamp closes.
 - b. Use an alcohol-dampened wipe to clean the drum. Press the **TEST PRINT** or **CLEAN PRINT HEAD** buttons to rotate the drum. Clean the drum only when it is not moving. Be sure to clean the entire drum.

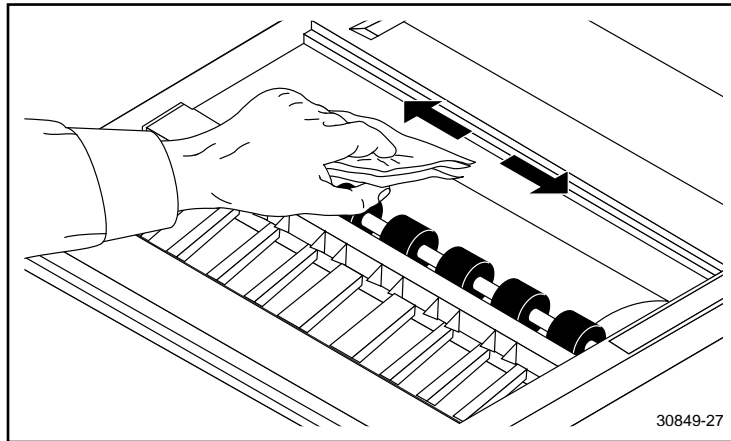

If wiping the drum by hand does not remove the ink, go to Steps **c** and **d**.

4 *Caring for Your Printer*

- c. Wrap the cleaning tool with an alcohol-dampened wipe.
- d. Clean the drum using a back-and-forth motion with the cleaning tool.

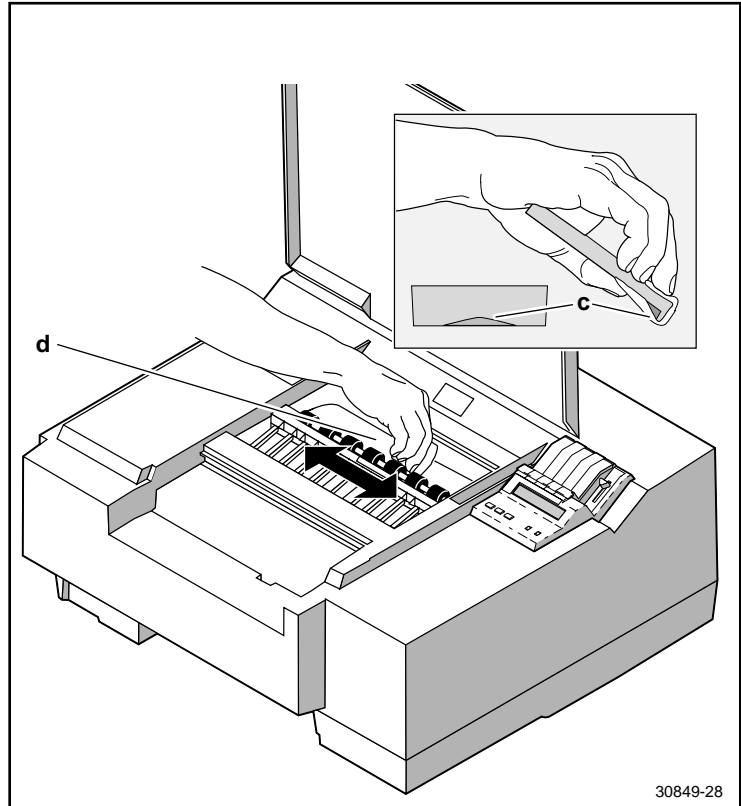

11. Close both covers when you finish cleaning the printer.
12. Press the **TEST PRINT** button until you see this message on the front panel:

```
Utilities      Vx.xx  
Exit          Next
```

13. Press the **CLEAN PRINT HEAD** button to exit **Utilities** mode.
14. Make a test print (you might need to make a few test prints to clear any residual ink). If, after making the test prints, you still see streaks or spots on the print, refer to Chapter 6, "Troubleshooting."

Cleaning the head wiper

1. If your prints have missing dots in a vertical row or a missing horizontal line, first press the **CLEAN PRINT HEAD** button on the front panel to clean the printhead. If that does not clear the problem, clean the head wiper:
2. Make sure that the Ready message appears in the front panel.
 - a. Open the top and rear covers.

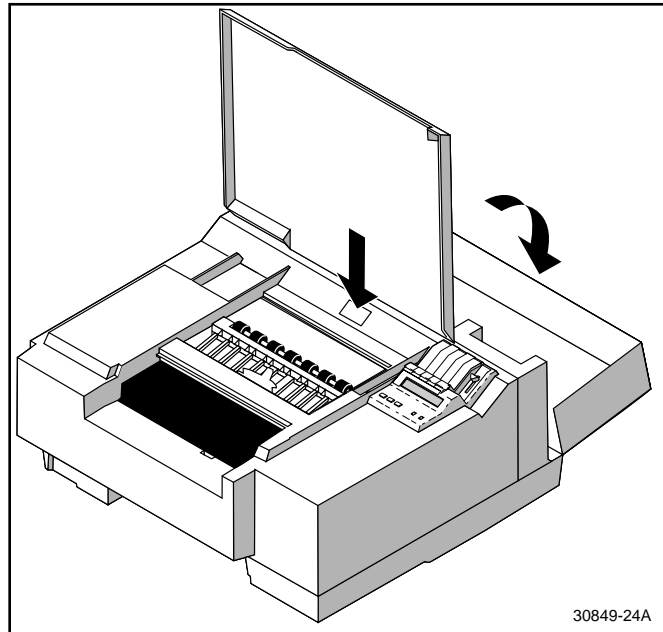

Warning *The printhead is hot. Do not touch it.*

Caution *Never scrape the head wiper with a tool or your fingertip because you could damage it. Clean the head wiper with an alcohol-dampened swab only.*

- b. Use an alcohol-dampened foam swab to clean the head wiper.

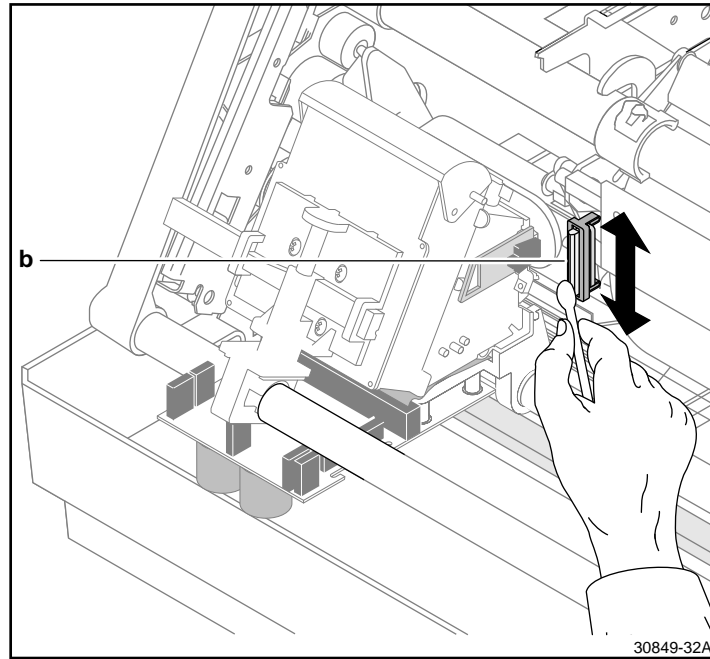

- c. Close the top and rear covers.
- d. Press the **CLEAN PRINT HEAD** button.

Cleaning the fuser rollers

If you are using shiny or smooth paper, you may occasionally see spots of ink in the white portion of the printed image, or you may notice that areas of the image are missing. These print defects can indicate that ink is being transferred from the printed paper to the fuser roller.

To correct the problem, first try these quick steps:

Quick Steps

1. Use a less shiny type of paper.
2. Make several test prints on standard office Bond paper (laser printer or photocopy paper). To do this, press the **TEST PRINT** button on the front panel. Be sure to load the paper so that the long side of the paper enters the printer first, as shown.

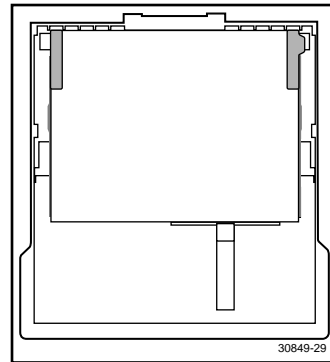

You should see a repeating pattern of ink spots on the blank part of the paper, indicating that the ink has transferred from the fuser onto the paper.

3. If the problem persists, replace the fuser wiper (refer to “Changing the fuser wiper” on page 4-4 for details).

If the problem continues, follow these procedures, explained in detail on the following pages:

- **Procedure A:** Enter **Utilities** mode and clean the fuser with blank paper.
- **Procedure B:** Enter **Utilities** mode and clean the fuser roller with the fuser cleaning pad.

Note *For your convenience, you may order a package of five fuser wiper pads (order number 650-2564-00); call the Tektronix Graphics Supplies Order Desk toll-free in the U.S. at 1-800-835-6100, or call your local Tektronix dealer.*

Procedure A

When you perform this procedure, the printer must be in **Utilities** mode.

1. When the printer is on and the Ready message appears in the front panel, press the **UTILITIES** button. You see this message (*Vx.xx* is the firmware version number):

```
Utilities      Vx.xx
Exit          Next
```

2. Press the **TEST PRINT** button several times to reach this message:

```
Clean fuser
Start      Next
```

3. Load 10 sheets of standard office Bond paper (laser printer or photocopy paper) into the paper tray. Be sure to load the paper so that the long side of the paper enters the printer first, as shown in "Quick Steps."
4. Press the **CLEAN PRINT HEAD** button.
 - After you press the button, the printer loads and ejects the 10 sheets of paper. If ink is visible on the tenth sheet, repeat Steps 3 and 4.
 - If the paper continues to have ink spots, go to Procedure B.
 - If the ink spots do not appear on the paper, continue with Step 5 to return the printer to normal operation.
5. Return to normal operation by pressing the **TEST PRINT** button to reach this display:

```
Utilities      Vx.xx
Exit          Next
```

6. Press the **CLEAN PRINT HEAD** button to exit **Utilities** mode.

Procedure B

When you perform this procedure, the printer must be in **Utilities** mode.

1. When the printer is on and the Ready message appears in the front panel, press the **UTILITIES** button. You see this message (where *Vx.xx* is the firmware version number):

```
Utilities      Vx.xx
Exit          Next
```

2. Press the **TEST PRINT** button until this message appears in the front panel:

```
Clean fuser
Start      Next
```

3. Remove the paper tray.
4. Load 10 sheets of standard office Bond paper (laser printer or photocopy paper) into the paper tray. Do not install the paper tray at this time. Be sure to load the paper so that the long side of the paper enters the printer first, as shown in "Quick Steps."

5. Remove the fuser wiper from the printer.

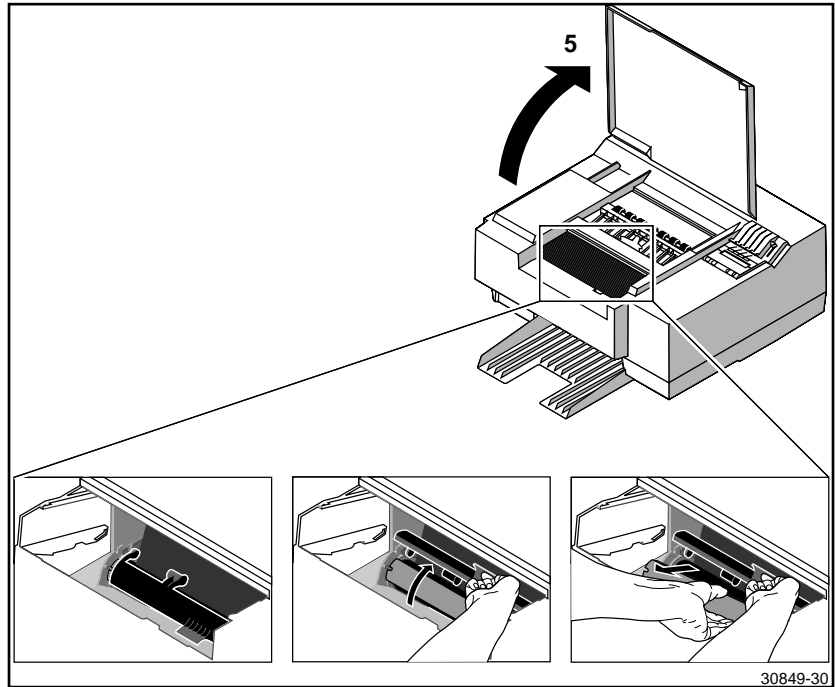

30849-30

6. Using isopropyl alcohol, dampen one of the felt strips on the fuser cleaning pad.

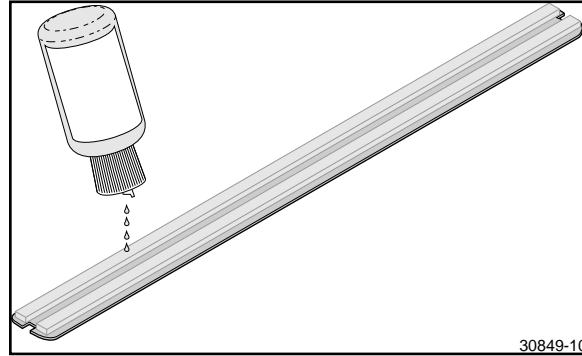

7. Install the fuser cleaning pad into the printer. Install the pad so that the alcohol-dampened section is down (**A**).

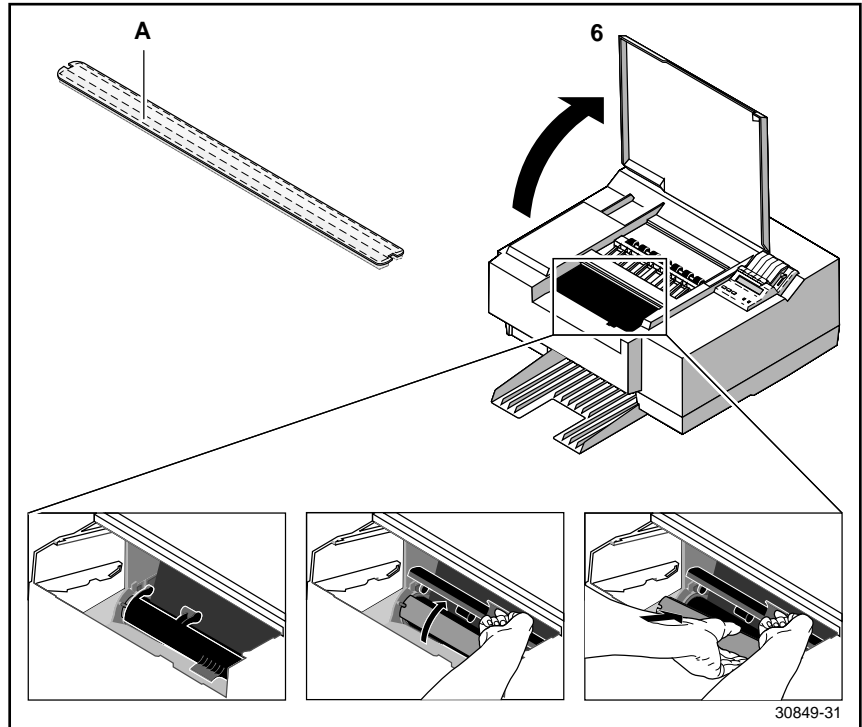

8. Install the paper tray.
9. Press the **CLEAN PRINT HEAD** button.

After you press the button, the printer feeds the 10 sheets of paper through the printer so that the fuser cleaning pad cleans the fuser roller.

10. Remove the paper tray.
11. Remove the fuser cleaning pad.
12. Install a new fuser wiper.
13. Load another 10 sheets of standard office Bond paper (laser printer or photocopy paper) into the paper tray. Be sure to load the paper so that the long side of the paper enters the printer first, as shown on page 4-22.
14. Install the paper tray.
15. Press the **CLEAN PRINT HEAD** button.

After you press the button, the printer feeds the 10 sheets of paper through the printer.

If any ink is visible on the paper, repeat Steps 13, 14, and 15.

16. Return to normal operation by pressing the **TEST PRINT** button to reach this display:

```
Utilities      Vx.xx
Exit          Next
```

17. Press the **CLEAN PRINT HEAD** button to exit **Utilities** mode.

Supplies and Accessories

Tektronix supplies: the mark of quality

Tektronix supplies are developed and tested as a total *system* — printer, ink, and media. These system components work together to produce consistent, high-quality color images.

Always order Tektronix supplies for your printer to guarantee the best results.

Ordering information

To order supplies such as paper or ColorStix ink, refer to the supplies information sheet that came with the printer and contact your local dealer or, in the United States, call Tektronix at **1-800-835-6100**. Refer to the following table for a listing of many supplies and accessories for the Phaser 300X.

Phaser 300X supplies and accessories

ColorStix in sticks		
016-1123-00	Black ColorStix	8 ink sticks per box; includes fuser wiper
016-1124-00	Cyan ColorStix	8 ink sticks per box
016-1125-00	Magenta ColorStix	8 ink sticks per box
016-1126-00	Yellow ColorStix	8 ink sticks per box
Cleaning supplies		
016-1144-01	Cleaning kit	
006-7824-00	Pack of 10 pre-soaked alcohol cleaning cloths	

Phaser 300X supplies and accessories (cont'd.)

Media trays		
436-0222-02	Universal paper tray	
436-0224-01	A/A4-size paper tray	
Media		
■ Paper, Bond (Premium) 24-lb. (90 g/m ²); 500 sheets/pack		
016-1137-00	A-size	8.5 x 11 in.
016-1138-00	A4-size	210 x 297 mm
016-1139-00	B-size (Tabloid)	11 x 17 in.
016-1140-00	A3-size	297 x 420 mm
016-1149-01	Tabloid Extra-size	12 x 18 in. / 305 x 457 mm
■ Paper, Cover 65-lb. (176 g/m ²); 250 sheets/pack		
016-1142-00	A-size	8.5 x 11 in.
016-1143-00	A4-size	210 x 297 mm
016-1141-00	Tabloid Extra-size	12 x 18 in. / 305 x 457 mm
■ Transparency film 100 sheets/box		
016-1103-00	A-size	8.5 x 11 in.
016-1104-00	A4-size	210 x 297 mm
■ Design transparency 50 sheets/box		
016-1219-00	B-size (Tabloid)	11 x 17 in.
016-1220-00	A3-size	297 x 420 mm
■ Transparency sleeves 50 sleeves/box		
016-1130-00	A-size	8.5 x 11 in.
016-1131-00	A4-size	210 x 297 mm
■ Transparency pockets 50 pockets/box		
016-1194-00	A-size	8.5 x 11 in.
■ Lamination sheets and folders 100/pack		
016-1163-00	A-size	8.5 x 11 in.
016-1164-00	A4-size	210 x 297 mm

Phaser 300X supplies and accessories (cont'd.)

Manuals	
070-8873-01	<i>Phaser 300X Color Printer User Manual (English)</i>
070-8873-11	<i>Phaser 300X Color Printer User Manual (French)</i>
070-8873-21	<i>Phaser 300X Color Printer User Manual (Italian)</i>
070-8873-31	<i>Phaser 300X Color Printer User Manual (German)</i>
070-8873-41	<i>Phaser 300X Color Printer User Manual (Spanish)</i>
070-8875-01	<i>Phaser 300X Drivers and Utilities Printing Reference</i>
070-8901-01	<i>Network Utilities for Phaser Color Printers Manual</i>
070-9270-00	<i>PhaserMatch User Manual and Addendum</i>
External SCSI disk	
Z350DSK	2.1 Gbyte, external, SCSI hard disk drive and cable
Laminator	
469LAM	Phaser Media Laminator

Upgrade kits

The following upgrade kits are available for the Phaser 300X.

Phaser 300X upgrade kits

Z300XUP	Upgrade a Phaser 300i to Phaser 300X (includes PhaserMatch; requires 22 Mbytes and Ethernet configuration)
4690F4M (order 1)	Adds 4 Mbytes of RAM (total of 14 Mbytes)
(order 3)	Adds 12 Mbytes of RAM (total of 22 Mbytes)
Z350DSK	SCSI hard disk for storage of additional downloaded fonts
4680FP1	Ethernet Interface hardware
4699FSS	Media startup kit: contains three each of cyan, magental, yellow, and black ink sticks; also premium transparency film
Z300XFX	Add PhaserMatch functionality (requires 22 Mbytes and Ethernet configuration)
4690F20	PhaserPrint software for UNIX workstations
4690F27	EasyCopy/X software for DEC OpenVMS AXP/1 workstations
4690F29	EasyCopy/X software for DEC OpenVMS VAX workstations
4690F41	PhaserSym print symbiont

Interface cables and Ethernet adapters

The following cables and Ethernet adapters are available through Tektronix or your dealer. Contact your dealer for Ethernet cables, LocalTalk adapters, and LocalTalk cables.

Phaser 300X interface cables and adapters

Tektronix order number	Connectors and cable length	Description
012-1468-00	36-pin plug to 25-pin plug; 3 meters (9.84 feet)	Parallel/Centronics cable
013-0299-00	Converts 36-pin low-density plug to 36-pin high-density plug	Parallel adapter
012-1380-00	9-socket receptacle to 25-socket receptacle; 3 meters (9.84 feet)	Serial (RS-232) Null modem
012-1379-00	9-socket receptacle to 9-socket receptacle; 3 meters (9.84 feet)	Serial (RS-232) Null modem
012-1465-00	50-position plug to 50-position plug; 2.5 meters (8.25 feet)	SCSI-II to SCSI-II
012-1299-00	50-pin low-density plug to Macintosh SCSI 25-pin plug	SCSI-1 LD to Macintosh SCSI cable
013-0297-00	Converts 50-pin low-density plug to 50-pin high-density plug	SCSI-1 LD to SCSI-2 HD adapter
AppleTalk	If AppleTalk connection is required, use either: PN-208 PhoneNet M2068 Apple's LocalTalk adapter <i>(Not available from Tektronix)</i>	

Ethernet adapters

Tektronix order number	Adapter type
011-0161-00	Thin coax (10Base2)
011-0160-00	Thick AUI (10Base5)
011-0162-00	Twisted pair (10BaseT)

Troubleshooting

If you need help

If you need assistance, contact your local Tektronix dealer or sales representative or any of these listed resources:

Type of service	How to access	Details
Customer Support Hotline	1-800-835-6100 US & Canada	Monday through Friday 6:00 am to 5:00 pm PST
Printer service	1-800-835-6100 US & Canada Outside US & Canada: contact local Tektronix dealer or office	Monday through Friday 6:00 am to 5:00 pm PST
The Tektronix Bulletin Board Service (BBS)	(503) 685-4504	24 hours/day, 7 days/week
Online services		
Technical support:	support@ColorPrinters.tek.com	
World Wide Web	http://www.tek.com/Color_Printers/	
Anonymous ftp server	ftp.tek.com/Color_Printers	
America Online	keyword Tektronix	
CompuServe	go Tektronix	
HAL automated fax system	(503) 682-7450 direct outside US, Canada	24 hours/day, 7 days/week
	1-800-835-6100 toll-free for US, Canada	24 hours/day, 7 days/week
EuroHAL	Refer to "Using the automated fax systems" on page 6-2.	24 hours/day, 7 days/week

Using the automated fax systems

As an alternative to other resources, and to provide up-to-date information quickly, Tektronix has set up HAL (Highly Automated Library) and EuroHAL, two interactive, automated fax systems. These automated fax systems provide Macintosh, PC, and workstation users with the latest technical hints and tips (like color adjustments), solutions to common technical problems, and application notes for software problems.

If you have a fax machine and a touch-tone voice telephone, you can order a HAL catalog, listing all of the information offered by HAL. You may call HAL or EuroHAL from anywhere in the world. The fax systems are available 24 hours a day, seven days a week.

Use EuroHAL to order a catalog or individual documents in Europe

EuroHAL includes many documents, some in English and some in other European languages. If a local version of the document you want is available, EuroHAL will send it in your language. Otherwise, it will send English documents.

Country	Numbers
Austria	
Belgium	
Denmark	00 44 1908 681 839
Finland	
Italy	
Switzerland	
France	05 90 81 86
Germany	0130 819 220
Holland	09 44 1908 681 839
Norway	095 44 1908 681 839
Spain	07 44 1908 681 839
Sweden	009 44 1908 681 839
UK	01908 681 839
Other countries	+44 1908 681 839 (where + is your country's International Access Code)

Error codes and front panel messages

A numeric code may appear in the front panel message area when the printer detects an error. Try cycling power on the printer. If that does not solve the problem, then call your dealer or Tektronix for assistance at **1-800-835-6100**.

Some messages, such as **STANDBY**, provide status information only. Those messages do not require user intervention. Other messages, such as **JAM — OUTPUT TRAY**, require you to perform some action such as remove a paper jam.

Caution *To avoid damaging the printer, do not turn the printer off when any of the following messages appear in the front panel message area: Busy Cleaning Head, Printing, or Utilities, unless you turn the printer back on within 5 minutes.*

Error codes and front panel messages

Message	Action
Busy < message >	No user action required.
Continue? See manual	You have pressed the CLEAN PRINT HEAD button five or more times. See “Using the CLEAN PRINT HEAD button.” If you want to continue cleaning and purge more ink, press the button again; otherwise the message clears in 10 seconds.
Initializing	No user action required.
Interface error	Turn the printer off then on again.
Jam — < location >	Remove the paper jam. See the label under the top cover for the location of the jam. The paper could be too thick or too thin.
Jam — Internal	<ol style="list-style-type: none"> 1. Check the 5 jam locations (see the label under the top cover); clear if necessary. 2. If the message still displays, cycle the power. 3. Clean the drum if the message still displays. 4. If the message still displays, write down the error code number from the front panel and call the Customer Support Hotline or your local Tektronix office.

Error codes and front panel messages (cont'd.)

Message	Action
Jam — Paper long	The paper is too long. Remove the jammed paper. Use shorter paper.
Jam — Paper narrow	The paper is too narrow. Remove the jammed paper. Use wider paper.
Jam — Paper short	The paper is too short. Remove the jammed paper. Use longer paper.
Printing	No user action required.
Processing data	No user action required.
Pull ink load lever	After you add an ink stick, close the ink cover and pull down the ink load lever.
Ready	No user action required. The printer is ready to print.
Standby	Press TEST PRINT to bring the printer to Ready.
Stopped — Add < color >	The printer needs ink of this color. Add another ColorStix ink stick.
Stopped — Add paper	Add paper, or install the paper tray.
Stopped — Close rear door	Close the rear cover.
Stopped — Close top door	Close the top cover.
Stopped — Close waste bin	Close the waste bin.
Stopped — Empty waste bin	The waste bin needs to be emptied, or was replaced too quickly after being emptied.
Stopped — For hand feed	Insert paper for manual feed.
Stopped — Remove < color >	The printer does not need ink of this color. Remove the ink stick.
System failure. Service required	Turn the printer off then on again. If the failure persists, note the code number in the display and call your dealer, or Tektronix service in the U.S. only at 1-800-547-8949.
Utilities	The printer is in Utilities mode. You can use this mode to set the language on the front panel, clean the printer, check the copy (print) count, empty the waste bin, clean the fuser, and adjust head convergence.
Wait to add < color >	Wait up to 15 minutes before adding another ink stick.
Waiting for Data	No user action required.

Clearing paper jams

To avoid paper jams, load the paper correctly into the paper tray, use Tektronix transparencies, and use paper grades such as Book, Bond, or Text in the paper tray. Use manual feed for thick papers, short papers, and envelopes. Keep paper and other supplies clean and free from dust.

Note To avoid paper jams, clean the printer periodically. Refer to "Cleaning the printer" on page 4-8 for cleaning details.

Paper jams can occur in these places:

1. At the paper tray
2. At the manual feed slot
3. Inside the printer
4. Near the output tray slot
5. In the rear of the printer

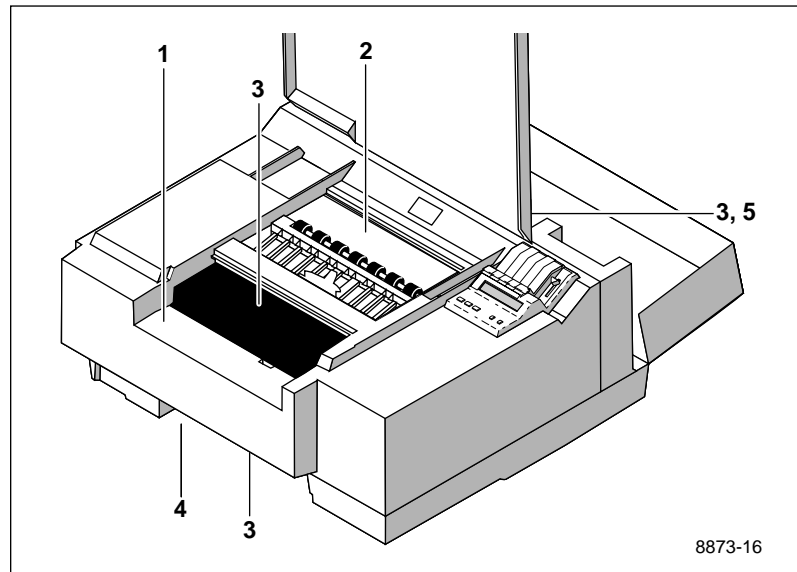

Removing jammed paper

Follow these guidelines when you remove jammed paper:

- Gently pull on the paper. Use both hands, if possible.
- Do not force the paper; it may tear. If the paper does not come out in one direction, try pulling the paper out from the opposite direction.
- After removing the jammed paper, inspect it for tears. Leave no paper scraps in the printer.
- After clearing the paper jam, load the paper tray properly.

Refer to the steps on the next page to remove jammed paper.

1. Press down to ease the tension on the rollers so that you can remove the paper jam.
2. Pull on the paper to remove the jam.

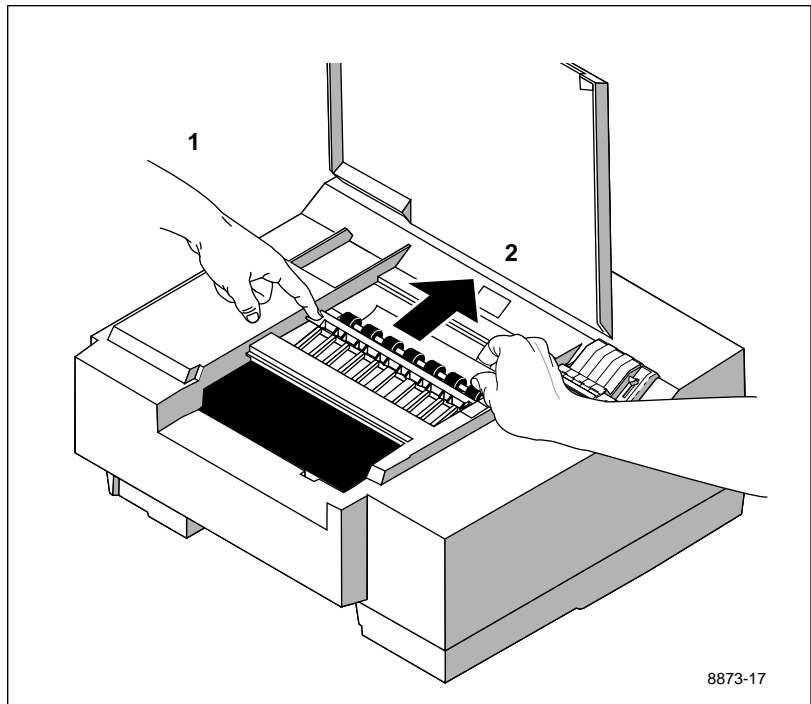

8873-17

Removing a paper jam from the rear of the printer

Warning *The printhead is hot. Do not touch it.*

1. Pull the cable sideways to move the printhead out of the way, if necessary.
2. Pull out the paper.

Note *When the rear cover is open, the printer starts to cool down. After you remove the paper jam, the printer may take a few minutes to warm up before it is ready to print.*

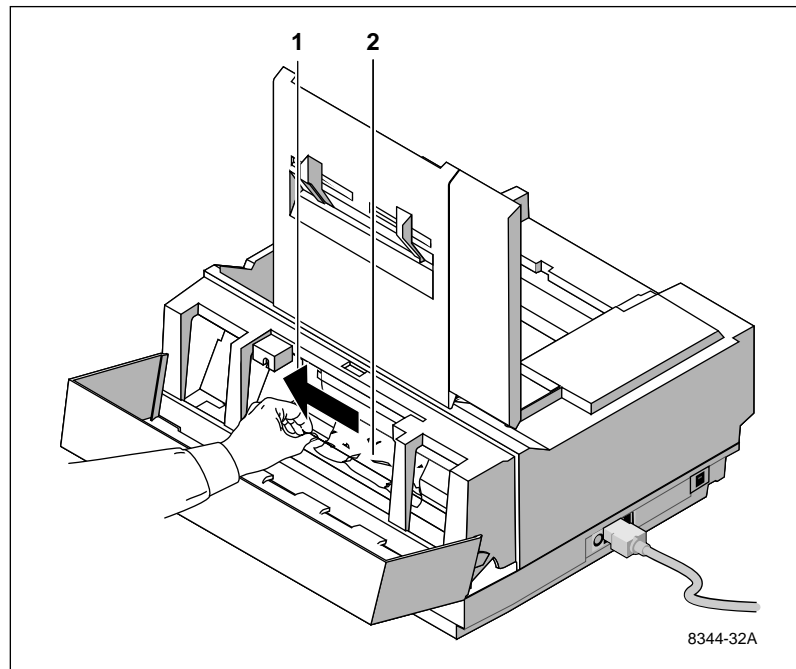

Setting head convergence

When you make a print, a vertical line should appear straight. If the vertical line is not straight, you can use the **Utilities** mode (through the **UTILITIES** button on the front panel) to adjust the head convergence, slightly.

You can check the head convergence by making a test print with the **TEST PRINT** button.

Test print example

The test print shows four head convergence test patterns.

- **A** Standard print quality row has three test patterns.
- **B** Enhanced print quality row has one test pattern.

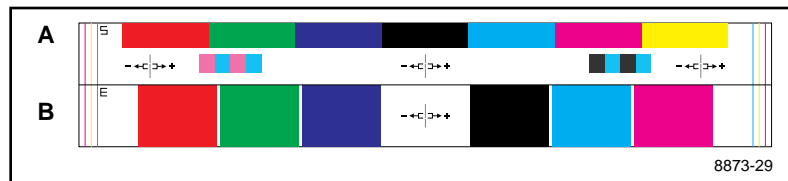

The following illustration shows four head convergence examples:

1. An example of good head convergence.
2. Head convergence needs adjusting: negative offset adjustment needed.
3. Head convergence needs adjusting: positive offset adjustment needed.
4. One pattern looks good, but the other two are misaligned. Call your nearest Tektronix dealer or, in the United States, call Tektronix service at 1-800-547-8949.

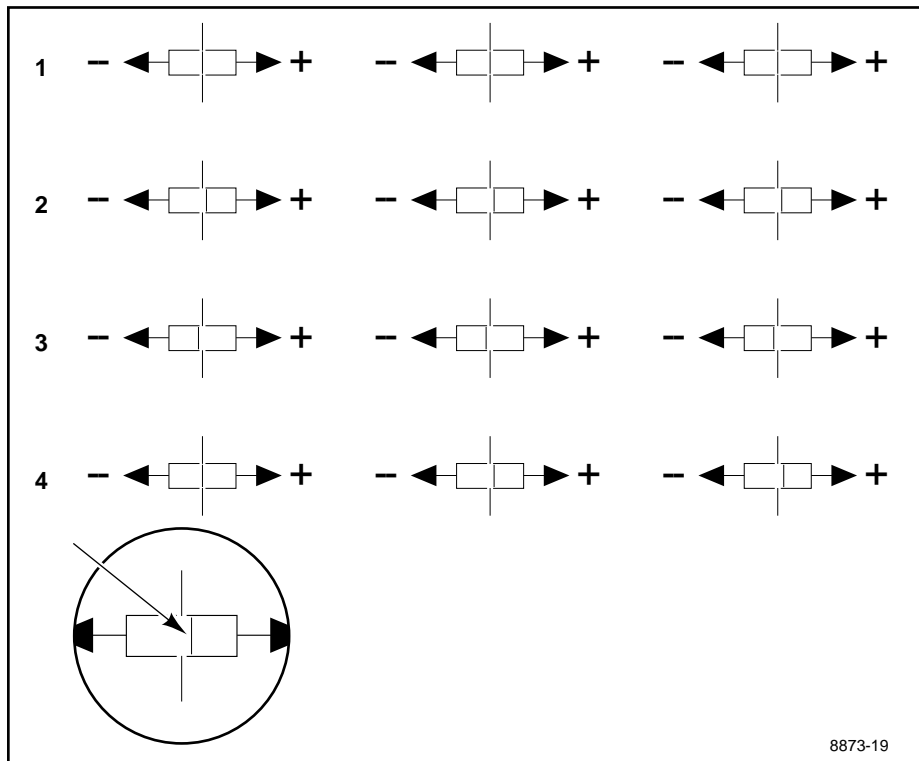

To correct the head convergence:

1. Press the **TEST PRINT** button to make a test print.
2. Examine the head convergence test patterns on the test print.
3. When the Ready message appears in the front panel, press the **UTILITIES** button to enter **Utilities** mode and adjust the head convergence. You see this message (Vx.xx is the software version number):

```
Utilities    Vx.xx
Exit        Next
```

4. Press the **TEST PRINT** button several times until the Head convergence message appears in the front panel. (In this example, *nn* represents the current setting.)

```
Head convergence  <nn>
Change           Next
```

5. Press the **CLEAN PRINT HEAD** button to change the settings for the head convergence. The choices, in increments of 1/4-pixel, are *0*, *+1*, *+2*, *+3*, *+4*, *-4*, *-3*, *-2*, *-1*, and *0*.

In the following example, select a higher number than the current setting to move the center line to the right. For example, if the current setting is *0*, select *+1*.

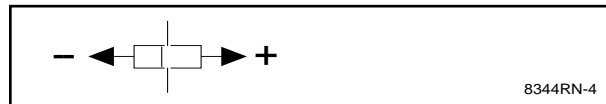

If the head convergence test pattern resembles the following example, select a number that is lower than the current setting to move the center line to the left. For example, if the current setting is **+0**, select **-1**. (Factory default is **0**.)

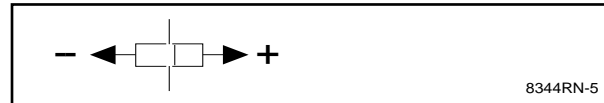

If the proper head convergence cannot be achieved by using the **-4** to **+4** range, there may be a problem with the printer. Call your dealer or Tektronix service.

6. Press the **TEST PRINT** button several times to return to this message.

Utilities	Vx.xx
Exit	Next

7. Press the **CLEAN PRINT HEAD** button to exit the **Utilities** mode.
8. Make another test print to check the results.

General cleaning guide

Most common problems can be avoided or solved by cleaning the printer regularly.

Problem type	Description	Solution
Paper-feed problems	Frequent paper jams or paper-pick problems	Clean the paper-pick rollers
		Clean the feed rollers
Image quality problems	Prints have streaks of ink	Clean the paper tension blade
	Prints have spots of ink on the top of the print	Clean the paper clamp
	Prints have spots of ink on the back of the print	Clean the drum
	Prints have spots of ink on the blank part of the page	Replace the fuser wiper Clean the fuser roller
	Areas of the image are missing	
	Prints with a vertical row of dots has one dot offset from others	Clean the head wiper
Internal Jam	Front panel displays this error message	Clean the drum
		Clean the paper clamp

Problems, solutions, hints

Refer to the following lists when you encounter problems with the printer. The paragraphs are divided into these categories:

- Print quality problems
- Network problems
- Operation hints
- Printer standby modes
- Printing and installation

Print quality problems

Missing lines. If your prints have missing lines similar to this illustration, follow this procedure that uses the **CLEAN PRINT HEAD** button to correct the problem.

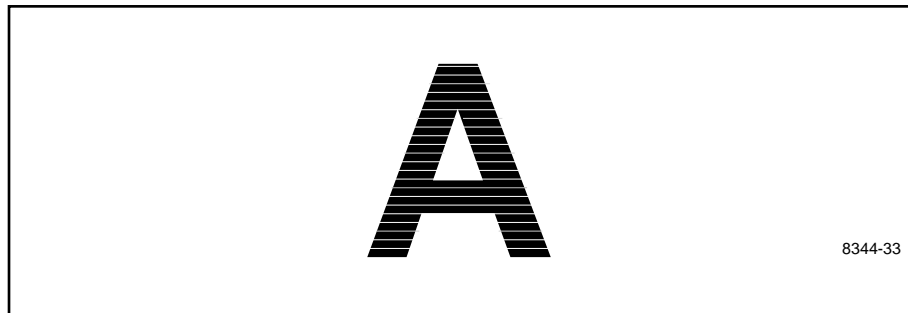

Note *The **CLEAN PRINT HEAD** button performs two cleaning operations: wipe or purge. During a wipe operation, the printhead passes a wiper that removes paper fibers from the face of the printhead. During a purge operation, the printhead expels ink to flush air out of the ink-jet nozzles of the printhead.*

*Whether the **CLEAN PRINT HEAD** button does a wipe or purge depends on the number of times you press the button and how many prints you have made before you press the button again.*

1. Press the **CLEAN PRINT HEAD** button one time. The printer performs a wipe operation that removes any paper fiber that might have accumulated on the printhead. When cleaning ends, the Ready message appears in the front panel.
2. Press the **TEST PRINT** button to make a test print. If the print still has missing lines, press the **CLEAN PRINT HEAD** button again.

The second time you press the **CLEAN PRINT HEAD** button, the printer purges ink. When the purging operation ends, the printer's front panel displays the Ready message. You can then make a print.

3. If the print still has missing lines, press the **CLEAN PRINT HEAD** button again. When you press the **CLEAN PRINT HEAD** button for a third time, and you have made less than three prints since the last time you pressed the **CLEAN PRINT HEAD** button, the printer executes a longer purge.

Note *When you make three or more prints between successive pressings of the **CLEAN PRINT HEAD** button, the cleaning cycle returns to the first stage and wipes the printhead the next time you press the button.*

4. If your prints still have missing lines (after pressing the **CLEAN PRINT HEAD** button three times), clean the wiper (see "Cleaning the head wiper" on page 4-20).

5. If cleaning the wiper does not correct the printing problem, and if your altitude is 4500 feet (1500 meters) or more above sea level, change the Head Drive mode:

- a. With the printer on and the Ready message displayed in the front panel, press the **UTILITIES** button to access the **Utilities** mode.
- b. Press the **TEST PRINT** button (**Next**) to scroll to the Head Drive mode. You see this message:

```
Head Drive:    1
Change        Next
```

- c. Press the **CLEAN PRINT HEAD** (**Change**) button so that the message reads:

```
Head Drive:    2
Change        Next
```

- d. Press the **TEST PRINT** (**Next**) button several times to return to the **Utilities** mode.
 - e. Press the **CLEAN PRINT HEAD** button (**Exit**) to exit the **Utilities** mode. The front panel displays the Ready message.
 - f. After changing the Head Drive mode, press the **CLEAN PRINT HEAD** button to execute another purge; then make another test print by pressing the **TEST PRINT** button.
6. If you still experience print quality problems, turn the printer off, wait at least 2 hours, then turn the printer on again. This “temperature cycle” cleaning may solve the problem.
7. If print quality problems persist after the temperature cycle, call a service representative (refer to “If you need help” on page 6-1). You may have a malfunctioning ink-jet.

Large spots or blobs of ink appear on the print. Spots that appear only on the back of the paper indicate a dirty drum. Spots on the image side or front of the paper indicate that the fuser wiper needs to be replaced. Refer to “Changing the fuser wiper” on page 4-4 for details on replacing the fuser wiper.

Small spots of ink are randomly scattered across the page. Make a test print. If the spots are still present, change the fuser wiper (refer to “Changing the fuser wiper” on page 4-4 for details).

Small or light ink specks appear anywhere on the edge. Clean the paper clamp. Refer to “Cleaning the paper tension blade, paper clamp, and drum” on page 4-13 for details.

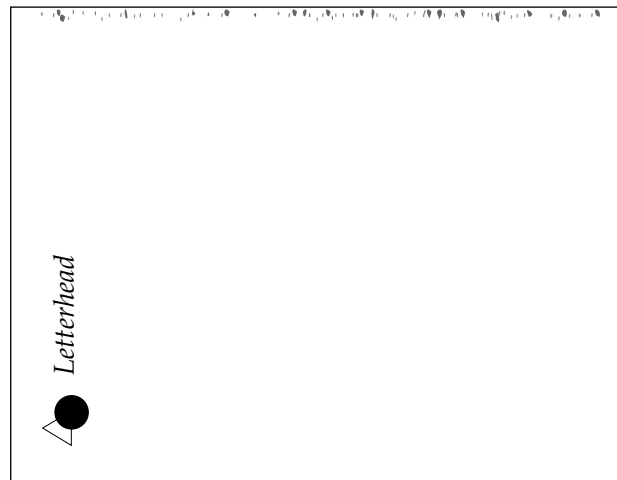

8344-37

Frequent stray ink marks or gaps of ink appear on the prints. Select a different type of paper. Refer to “All about media” on page 3-24 for details on what type of paper works best with the printer.

Stray ink marks or missing areas of the image. Try using a different type paper and change the fuser wiper. If the problem continues, clean the fuser roller. Refer to “Cleaning the fuser rollers” on page 4-22 for details on cleaning the fuser roller.

Streaks appear on the paper. Clean the paper tension blade. Refer to “Cleaning the paper tension blade, paper clamp, and drum” on page 4-13 for details.

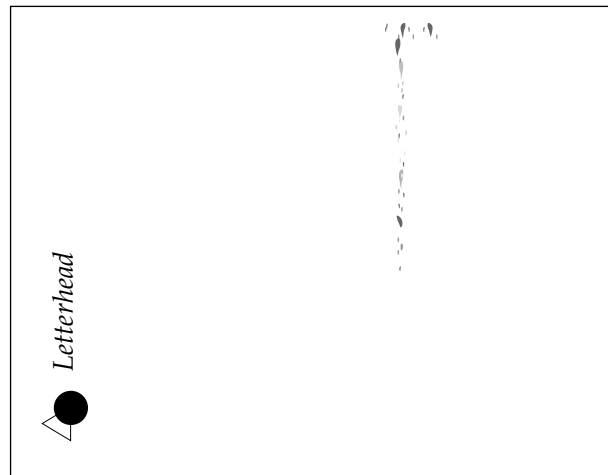

8344-34

A dark and heavy coat of ink appears that starts at either side of the page and runs toward the middle. Clean the printhead and use a different type of paper. Refer to “Print quality problems” on page 6-13 for details on how the **CLEAN PRINT HEAD** button works.

In vertical rows of dots, one row is offset from the others or missing. Make a test print (press the **TEST PRINT** button). If a row is offset, the ink from one of the ink jets is being deflected (**A**); if a row is missing, one of the ink jets is not functioning (**B**). Use the **CLEAN PRINT HEAD** button to clean the printhead; then make several test prints to help clean the paper path.

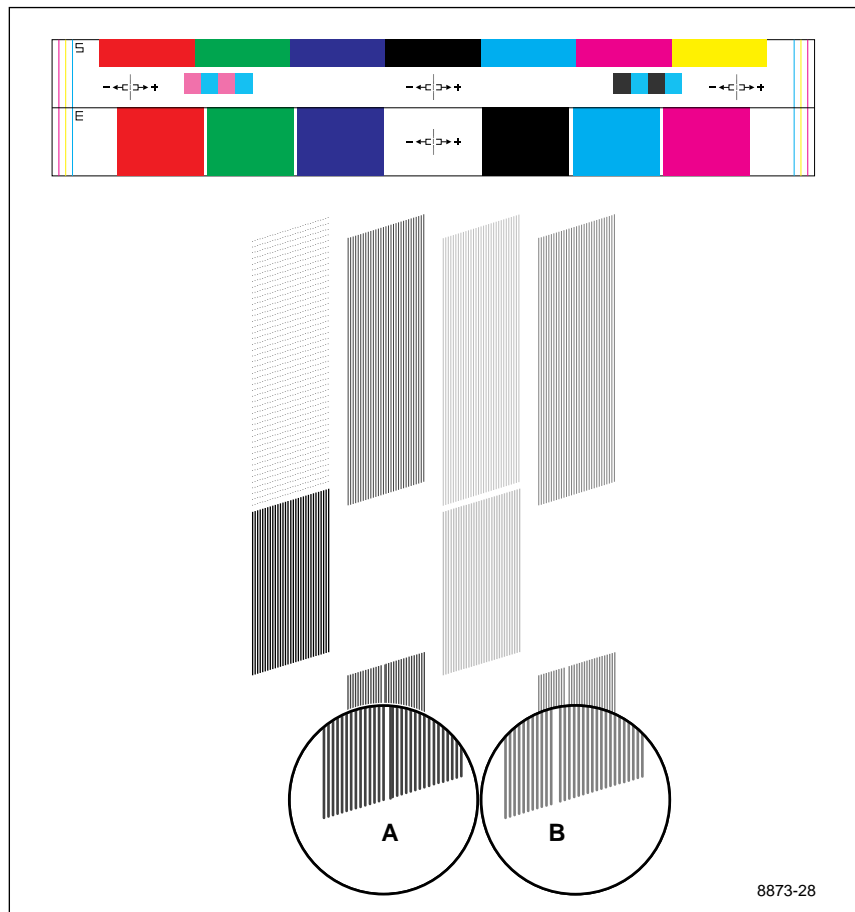

A vertical line appears to zigzag. If a vertical line does not appear straight, you may need to adjust the head convergence. Refer to “Setting head convergence” on page 6-8 for details.



Missing ink. Clean the paper tension blade. Refer to “Cleaning the paper tension blade, paper clamp, and drum” on page 4-13 for details.



Network problems

The printer doesn't appear in the Chooser. The printer is turned on with the cables correctly attached. Check the termination (refer to the documentation for your Ethernet adapter or LocalTalk connector for information on termination).

Select the correct zone in the **Chooser** before looking for the printer's name in the list of printers. If you have changed the printer's name, did you make it a unique name (not the same as any other printer in the zone)? Check the configuration page to get the zone name and printer name. Refer to "Generating a configuration page" on page A-2.

Make sure that the appropriate network interface (LocalTalk or EtherTalk) has been selected for the Macintosh and that you are using the most current network software (available from Apple).

Operation hints

The paper skews as it passes through the paper path. Make sure that the paper is not excessively curled. You may have to clean the paper clamp. Refer to “Cleaning the paper tension blade, paper clamp, and drum” on page 4-13 for details.

Frequent paper jams occur when you are using the paper tray. Load the paper properly into the paper tray. Use paper grades such as Book, Bond, or Text in the paper tray. Is the paper too thick or thin for the printer? Refer to “All about media” on page 3-24 for more details on the type of paper you can use with the printer and for metric paper grade equivalents. Or you may need to clean the paper-pick rollers. Refer to “Cleaning the paper-pick rollers” on page 4-11 for details on cleaning these rollers.

Printing on both sides of the paper. Use manual feed for the second side.

The paper jams while you are using manual feed. Set the paper guides so that the paper travels squarely into the printer. Feed the paper into the printer and let the printer take the paper out of your hands. Wait at least 5 seconds before inserting a second sheet. Is the paper too thin or thick for manual feed?

You pressed the TEST PRINT button and did not receive a test print. If the printer has been idle for more than 2 hours, you must press the TEST PRINT button again. See “Printer standby modes” on page 6-23 for more information.

The print is wrinkled. You may be using paper that is too thin for the printer or have its grain running in the wrong direction. Use a different type of paper or position the paper correctly. Paper grades such as Bond, Book, and Text work best with the printer. Refer to the table “Guidelines for paper grade, weight, and thickness” on page 3-26 for the metric paper grade equivalents.

When you requested Tabloid Extra media, the page doesn't print and you get a configuration error. You may have only 10-Mbytes of memory; in that case, the printer only accommodates paper up to B-size (Tabloid) or A3-size (Metric Tabloid).

Delayed printout. See “Printer standby modes” on page 6-23.

Turn off the startup page. Refer to the *Phaser 300X Drivers and Utilities Printing Reference*.

Leave the printer on. The printer has an automatic standby mode that keeps the printer ready to use and reduces energy consumption. When you turn off the printer, then turn it on again, it consumes ink; so, leaving the printer on saves ink. However, if you will not be printing for two or more days, turn the printer off.

After you turn on the printer, you should watch the first few messages that appear in the front panel. You may have to add ink or empty the waste bin before the printer continues the warm-up cycle.

The edge of the printed paper is rippled. Load paper into the printer with the paper’s grain parallel to the paper path (the direction the paper travels while it is fed through the printer). Refer to “All about media” on page 3-24 for more details on paper grain.

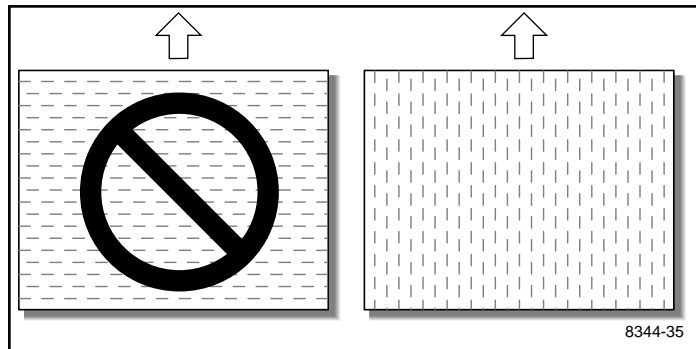

Printer standby modes

Idle for 2 hours. When the printer is idle for more than 2 hours, it goes into a standby mode that keeps the printer ready to use and reduces energy consumption.

The printer exits standby mode when you send a file to the printer, press one of the front panel buttons, or open the rear cover. For example, adding ink or changing the fuser wiper causes the printer to exit standby mode. The printer does not purge ink when it exits standby mode after being idle for 2 hours. When the printer exits standby mode, it is ready to print in about 5 minutes.

Idle for 2 days. When the printer is idle for 2 days or more, it cools down completely. When the printer exits the cool-down mode after being idle for 2 days, it purges ink as part of the warm-up cycle. The printer is ready to print in about 20 minutes.

Printing and installation

The image does not finish printing (the printer times out).

- **For PC users**

If you are using the serial or parallel port from a PC, use the **MODE** command to set the PC's communication parameters. For example:

```
MODE LPT1:,,P > NUL
MODE COM1:9600,N,8,1,P
```

- **For Windows users**

Open the **Control Panel**. Double-click the **Printers** icon. Choose your Tektronix printer. Click on the **Connect** button. Change the **Device Not Selected** timeout to 60. Change the **Transmission Retry** to 850. Place a check mark in the box **FAST Printing Direct to Port**. Turn the **Print Manager** off.

Which port is faster, parallel or serial? If you have a PC, you may want to use the parallel port because it is faster than the serial port.

Getting the largest printed picture. The area of paper that the printer prints on is smaller than the paper size. See "Margins and image area" on page 3-28 for more details. You may have to adjust the margins in your application software. To print the largest image possible on 300 x 450 mm (12 x 18 in.) paper, the printer should have at least 14 Mbytes of memory.

You have a Macintosh and the printed image has shifted or the margins are not correct. Refer to the topic "Printing from a Macintosh" on page 3-11 for details on how to print from a Macintosh. You should install the Phaser 300X printer driver onto your Macintosh in order to select the correct page sizes from the driver. Refer to the *Phaser 300X Drivers and Utilities Printing Reference* for details on the Phaser 300X driver.

The image prints in black-and-white instead of color.

- If you have a Macintosh, use the Phaser 300X driver or the Apple LaserWriter printer driver (version 6.0 or higher) that supports color PostScript. Select **Color/Grayscale** in the print dialog box. Refer to “Printing from a Macintosh” on page 3-11 for more details on how to print from a Macintosh.
- You may need to install specific application-related files such as PPDs, PDXs, and PDFs. Refer to the *Phaser 300X Drivers and Utilities Printing Reference* for information.
- Refer to the *Phaser 300X Drivers and Utilities Printing Reference* for information on the LaserWriter printer driver version 8.x.
- If you have a PC, be sure to use a driver that supports color PostScript. If you have Windows, use the Tektronix-supplied driver that was shipped with the printer’s software. Refer to the *Phaser 300X Drivers and Utilities Printing Reference* for information on the drivers.

The Ready message is displayed in the front panel, but the file does not print. Try printing the same file to another PostScript printer. If the file prints, then the problem could be with the interface cable.

For the best results, use Tektronix interface cables, especially if you are using the serial port. Refer to the table “Phaser 300X interface cables and adapters” on page 5-4 for a description of the Tektronix cables.

If the problem is not with the cable, refer to the *Phaser 300X Drivers and Utilities Printing Reference* for details on how to use the Tektronix Error Handler to determine the cause of the problem.

The file does not print and a virtual memory (VM) error message appears on the Macintosh screen. You may need to expand printer memory. Refer to Appendix B “Expanding Your Printing System” for more information.

The file does not print or it prints garbage data. Make sure that you have selected the appropriate language (PostScript, HP-GL, or PCL5) for that file. Refer to “Switching printer languages” on page 3-41.

You want to make the largest image possible on Tabloid Extra paper (305 x 457 mm or 12 x 18 in.). The printer should have at least 14 Mbytes of memory. Refer to “Margins and image area” on page 3-28 and “Advantages of adding memory” on page B-3.

You are using manual feed and part of the image does not print or the image orientation was not correct. You may have manually fed paper without having selected **Manual Feed** in the driver. Check the paper tray. The orientation (long side or short side of the paper enters the printer first) of manual feed must match the orientation of the paper tray. Select **Manual Feed** and the correct orientation from the printer driver. Change the direction of the manual feed, or change the direction of the paper in the paper tray. When using the paper tray, load the transparencies with the white strip (Tek[®] logo) and blue arrows entering the printer first.

The image is clipped or rotated. Make sure that the paper is correctly installed in the paper tray. The rear guide in the paper tray must be positioned snugly against the paper.

A clipped or rotated image can result if you have selected the wrong printer in the **Chooser**. Make sure that you choose the complete and exact name of your printer.

Color corrections. Refer to the *Phaser 300X Drivers and Utilities Printing Reference* for details on how to select color corrections.

Files sent to the printer during power-up do not print. Before printing a file, wait until the printer's front panel displays READY. Some applications, drivers, and spoolers report IDLE when the printer is ready to accept print jobs.

The printer receives files but does not print (serial and parallel ports only). Do not set the wait timeout to 0. Also, print files should not have extra characters after the End-of-Job character (Ctrl-D). See the *Phaser 300X Drivers and Utilities Printing Reference* for information on setting timeouts and the Ctrl-D character.

You send a file to the printer's serial or parallel port, and the printer's front panel displays WAITING FOR DATA indefinitely. Another file sent to a different port causes your computer or network interface to lock up. Do not set the wait timeout to 0. Also, print files should not have extra characters after the End-of-Job character (Ctrl-D). See the *Phaser 300X Drivers and Utilities Printing Reference* for information on setting timeouts and the Ctrl-D character.

You send a file to the printer's serial or parallel port, and the job prints successfully. After the job prints, the printer displays WAITING FOR DATA, then goes into Standby mode after 2 hours. The printer doesn't come out of Standby mode for the next print job. To recover, press the TEST PRINT button or reset the printer. (If you reset the printer, you must send the print job again.) To prevent this condition, do not set the wait timeout to 0. Also, print files should not have extra characters after the End-of-File character (Ctrl-D). See the *Phaser 300X Drivers and Utilities Printing Reference* for information on setting timeouts and the Ctrl-D character.

The startup page prints although you disabled it. The printer's power-up self-test can detect problems that do not necessarily make the printer completely inoperable. Examples of these *non-fatal* errors include faulty printer ports and some memory failures.

If the printer detects a non-fatal error at power-up, the startup page prints, even if you have disabled it.

Front and Rear Panels

The front and rear panels on the Phaser 300X printer provide you with information about the printer's operation, as well as the ability to control the printing environment. Refer to "Error codes and front panel messages" on page 6-3 for a complete description of the front panel messages.

Front panel

1. **INK LEVEL:** Three icons that show how much ink is in the printer. Refer to the illustration of the front panel on the next page: the front panel displays one icon for each of the printer's four ink wells. The three icons have the following meaning:
 - a. Empty
 - b. Half-full
 - c. Full
2. **PRINTER STATUS:** Messages about the printer and actions required, if any.
3. **UTILITIES:** Press this button to access the **Utilities** mode, which is used to see how many prints the printer has made, to clean the printer, to clean the fuser, to adjust head convergence, or to empty the waste bin.
4. **CLEAN PRINT HEAD:** Press this button to clean the printhead. Refer to "Print quality problems" on page 6-13 for details on using this button. When in the **Utilities** mode, this button makes a selection of a specific function or changes a setting.
5. **TEST PRINT:** Press this button to print a basic test pattern, which consists of a color bar and vertical lines. The bars represent the seven basic colors: red, green, blue, black, cyan, magenta, and yellow. The vertical lines let you know that the ink-jet nozzles on the printhead are functioning properly. Refer to "Test print example" on page 6-8 for more details. When in the **Utilities** mode, this button allows you to scroll through a series of options.

6. **ERROR:** An indicator that lights up when the printer detects an error condition such as a paper jam.
7. **POWER:** An indicator that lights up when the printer is on and blinks when the printer processes data.
8. **INK COVER:** Open the ink cover to load the ColorStix ink. For details on how to load ink, see “Adding ink” on page 4-2.
9. **INK LOAD LEVER:** After dropping an ink stick into the ink loading bin, close the cover and pull down on the lever, then release it so that the ink drops into the printhead. For details on how to load ink, see “Adding ink” on page 4-2.

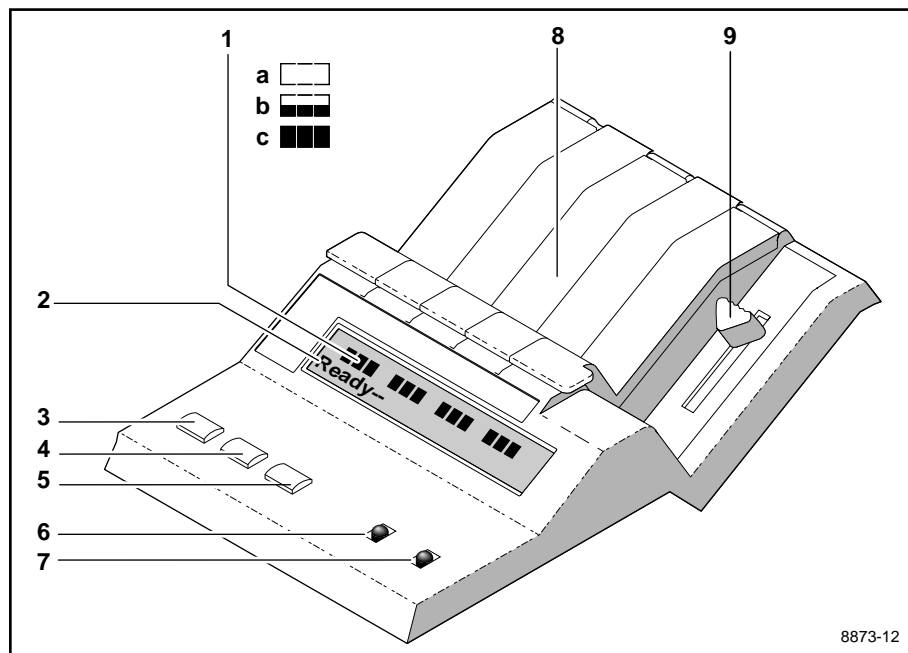

Utilities mode menu structure

Use the **Utilities** mode to select a language for the front panel, to see how many prints the printer has made, to clean the printer, to clean the fuser, to adjust head convergence, or to empty the waste bin.

To access the **Utilities** mode, press the **UTILITIES** button. You see this message:

```
Utilities      Vx.xx
Exit          Next
```

Here is the order of the messages as they appear in the **Utilities** mode. You scroll through the list by pressing the **TEST PRINT (Next)** button:

```
Utilities      Vx.xx
Exit          Next
```

```
Copy count
Next
```

```
Language: English
Change       Next
```

```
Cleaning mode
Start       Next
```

```
Clean fuser
Start       Next
```

```
Head convergence
Change     Next
```

```
Head drive    1
Change     Next
```

```
Waste bin
Unlock      Next
```

```
Utilities      Vx.xx
Exit          Next
```

Rear panel

Rear panel switches

Note Changes to rear panel **Switches 5, 6, and 7** do not take effect until you reset the printer or turn it off and back on again. Changes to **Switches 8 and 9** take effect immediately.

Rear panel switches

Switch	Function	Settings
1	Reset/run	<p><i>Up:</i> The printer resets and does not accept data while the switch is in this position.</p> <p><i>Down:</i> The printer runs a self-test, then proceeds to run normally. Leave the switch <i>down</i> for normal operation.</p>
2, 3, 4	Configuration Page/ Diagnostics	<p><i>Up:</i> When only Switch 4 is moved from <i>down</i> to <i>up</i>, the printer prints a configuration page. See the table “Switches 2, 3, and 4: Diagnostics” on page 7-6.</p>
5	Start Job	<p><i>Up:</i> The Sys/Start job on the hard disk does not run.</p> <p><i>Down:</i> The Sys/Start job runs if the file exists on the disk.</p>
6	Set paper size	<p><i>Up:</i> For metric-size media.</p> <p><i>Down:</i> For American-size media.</p>
7	Baud Rate	<p><i>Up:</i> Fixed. Sets the serial communication parameters to 1200 baud, software flagging, and ignore parity.</p> <p><i>Down:</i> Variable. Lets you change the serial communication parameters. The factory setting is 9600 baud, software flagging, and ignore parity.</p> <p>For information on how to change the serial port settings when Switch 7 is in the <i>down</i> position, refer to the <i>Phaser 300X Drivers and Utilities Printing Reference</i> for details on the setdevparams PostScript command.</p>
8 and 9	Color Correction	See the table “Switches 8 and 9: Color Correction Mode” on page 7-6.

Switches 2, 3, and 4: Diagnostics

Switch 2	Switch 3	Switch 4	Function
<i>Down</i>	<i>Down</i>	<i>Down</i>	Default, normal operation
<i>Down</i>	<i>Down</i>	<i>Up</i>	Prints a configuration page
<i>Up</i>	<i>Down</i>	<i>Up</i>	^a Demo page replaces the startup page

a. The demo page prints out at restart and power-up; however, if diagnostics senses an error during power-up, the startup page will be printed regardless of the switch settings.

Switches 8 and 9: Color Correction Mode

Switch 8	Switch 9	Function
<i>Down</i>	<i>Down</i>	No color correction
<i>Down</i>	<i>Up</i>	SWOP Press (matches output of a web offset press)
<i>Up</i>	<i>Down</i>	Vivid Blue
<i>Up</i>	<i>Up</i>	Use NVRAM (default setting is Euroscale Press)

Rear-panel LED indicator

The Phaser 300X has a single rear-panel LED that blinks to indicate that the printer's controller is operational. If the LED is not blinking after power-up and printing the first page call Customer Support (**1-800-835-6100** in the United States), or your local Tektronix office (outside the U.S.). Refer to "If you need help" on page 6-1.

A

Technical Notes

Startup and configuration pages

Turning off the startup page

You can disable the startup page by sending a PostScript language utility file (found on the printer's utilities diskette) to the printer. For details on how to turn off the startup page, refer to the *Phaser 300X Drivers and Utilities Printing Reference*.

Even when the startup page is turned on, you can stop the startup page from printing by removing the paper tray at power-up. Put the paper tray back in after the power-up sequence is complete.

If the printer has picked paper and is printing the startup page, it can be cancelled by lifting and lowering the printer top cover.

Generating a configuration page

The Phaser 300X can generate a configuration page that contains information that is useful in Ethernet installation and troubleshooting network problems.

There are two ways to generate the configuration page:

- **Use the printer's rear panel switches.**

1. Set **Switches 2, 3, and 4** *down*.
2. Set **Switch 4** *up*.

The printer generates the configuration page as soon as **Switch 4** is set (you do not have to reset the printer).

3. When the configuration page has printed, reset **Switch 4** to *down*.

- **Send the PostScript language file for printing the configuration page to the printer.**

See the manual *Network Utilities for Phaser Color Printers*, or the *Phaser 300X Drivers and Utilities Printing Reference* for more information on the configuration page.

Print count

The startup page lists the number of pages printed under General Information. You can also use the **Utilities** mode to check how many prints the printer has made. Refer to “Utilities mode menu structure” on page -4 for more information on the **Utilities** mode.

1. When the printer is on and the Ready message appears in the front panel, press the **UTILITIES** button. You see this message (*Vx.xx* is the firmware version number):

```
Utilities    Vx.xx
Exit        Next
```

In the **Utilities** mode, you can scroll through the menu selections using the **TEST PRINT** button (which corresponds to the front panel's messages *Next*), and execute a function or change a setting using the **CLEAN PRINT HEAD** button (which corresponds to the front panel's message *Exit*).

2. Press the **TEST PRINT** button to scroll through the **Utilities** mode menu until the Copy Count message appears in the front panel window. (In this example of the message, *nnn* represents the number of prints.)

```
Copy count
< nnn >    Next
```

3. Press the **TEST PRINT** button several times to return to this message.

```
Utilities    Vx.xx
Exit        Next
```

4. Press the **CLEAN PRINT HEAD** button to exit the **Utilities** mode.

Printer ports

LocalTalk and Ethernet ports

The LocalTalk and Ethernet ports implement a Printer Access Protocol (PAP) server that accepts only one connection at a time. The port's device type is LaserWriter. The printer implements AppleTalk, Phase 2 for the EtherTalk port. If you ordered your printer with the network option, you received the Network Utilities diskettes and the *Network Utilities for Phaser Color Printers User Manual*. Refer to that manual for complete information on Ethernet.

Printer name and AppleTalk zones

The Phaser 300X uses the same printer name on all ports. (The printer name is the name you see in the list of printers when you select the **Chooser**.) If you change the name on one port, the change effects all ports to keep them identical. This avoids confusion for users because they always see the same printer name regardless of the port selected.

If you set the Ethernet zone to be the same as the LocalTalk zone, the printer automatically modifies the name as seen on the LocalTalk network to be different from the name as seen on the Ethernet network. For example, the default printer name **Phaser 300X** would be changed to **Phaser 300X (via LocalTalk)**. (If necessary, the name is truncated to the 32-character limit.) This automatic renaming allows users to distinguish the high-speed Ethernet connection from the slower LocalTalk connection.

Parallel port

The printer has a standard unidirectional, byte-wide parallel, synchronous port. When you use the parallel port, be sure to type this command at the PC (if LPT1 is not available, use LPT2):

MODE LPT1:,,P

The table shows the parallel port's connected pins. Other pins are not connected. Signal names ending with a dash (–) are asserted low.

Parallel port signal descriptions

Signal name	Pin #	Return pin	Signal source	Description
DSTRB–	1	19	Host	Pulsed low for .5 microseconds minimum; clocks data into printer
DATA1	2	20	Host	Positive true data input
DATA2	3	21	Host	Positive true data input
DATA3	4	22	Host	Positive true data input
DATA4	5	23	Host	Positive true data input
DATA5	6	24	Host	Positive true data input
DATA6	7	25	Host	Positive true data input
DATA7	8	26	Host	Positive true data input
DATA8	9	27	Host	Positive true data input
ACK–	10	28	Printer	Data acknowledge pulsed low for 3-4 microseconds; ends bus transaction
BUSY	11	29	Printer	Positive true = cannot accept data
PE	12	—	Printer	Positive true = out of paper
SLCT	13	—	Printer	Positive true = printer selected
INPRIME–	31	30	Host	Negative true = printer port reset
FAULT–	32	—	Printer	Negative true = printer fault indicator
Frame Gnd	—	17	Printer	Frame ground
SGnd	—	14,16,33	Printer	Signal ground

Serial port

The printer's serial port provides an RS-232 interface connection to PCs and other hosts. The printer's serial port has these built-in default settings.

- Variable (factory default, **Switch 7, down**)
 - Baud rate — 9600
 - Flagging — Software (XON/XOFF)
 - Parity — None
 - Stop bits — 1
 - Data bits — 8
 - Check parity — False
 - Protocol — Normal

When **Switch 7** on the printer's rear panel is in the *down* position, you can change the default setting. To change the serial port's settings, you can use the PostScript Level 2 **setdevparams** command. Refer to the *Phaser 300X Drivers and Utilities Printing Reference* for details.

- Fixed (**Switch 7, up**)
 - Baud rate — 1200
 - Flagging — Software (XON/XOFF)
 - Parity — Space
 - Stop bits — 1
 - Data bits — 7
 - Check parity — False
 - Protocol — Normal

Some PCs and Unix hosts do not support **Space** parity. Usually they accept parity values of **odd**, **even**, or **none**. Therefore the closest setting is 1200 baud, 1 stop bit, 8 data bits and no parity, which has the following associated **MODE** statement:

MODE COM1: 1200, N, 8, 1, P

Space parity forces the parity bit to 0. For most users, 8 data bits and no parity is identical to 7 data bits and **Space** parity.

Serial port signals

The following table shows the printer's serial port pinout.

Serial port signal descriptions

Signal name	Pin #	Printer I/O	Description
DCD	1	In	Data carrier detect
RxData	2	In	Received data
TxData	3	Out	Transmitted data
DTR	4	Out	Data terminal ready
Gnd	5	—	Signal ground
DSR	6	In	Data set ready
RTS	7	Out	Request to send
CTS	8	In	Clear to send
RI	9	Out	Ring indicator

Specifications

Temperature

Operating: 10° C to 32° C (50° F to 89.6° F)
Nonoperating: -30° C to +60° C (-22° F to 140° F)
Storage: -30° C to +60° C (-22° F to 140° F)

Humidity

Operating: 20% to 80% Relative Humidity, noncondensing
Nonoperating: 10% to 95% Relative Humidity, noncondensing

Altitude

Operating: 0 to 2,440 meters (0 to 8,000 feet)
Nonoperating: 0 to 15,250 meters (0 to 50,000 feet)

Primary voltage ranges (switch-selectable)

87 – 128 VAC, 115 VAC nominal
174 – 250 VAC, 220 VAC nominal

Frequency range

48 to 66 Hz

Primary fusing

115 VAC, 10 Amps Type 3AG
220 VAC, 5 Amps Type Euro 5 x 20 mm

Printing resolution

300 dots-per-inch

Heat dissipation

325 Watts Standby
425 Watts Printing

Dimensions

Height: 34.3 cm (13.5 in.)
Depth: 68.6 cm (27 in.)
Width: 63.5 cm (25 in.)
Weight: 40.8 kg (89 lbs.)

Safety and emissions

- **Listed:** UL 1950 Information Technology Equipment.
- **CSA certified:** CSA Standard C22.2 No. 950–M 89, Safety of Information Technology Equipment, Including Electrical Business Equipment.
- **TÜV licensed:** IEC 950 and EN60950.
- Class B compliant computing device pursuant to sub-part J of Part 15 of FCC rules.
- Conforms to EC EN55022.

B

Expanding Your Printing System

Customizing your printer

Tektronix offers upgrade and accessory kits to expand your printer's capabilities. To order upgrade kits, refer to the supplies information sheet that was shipped with the printer and contact your local dealer or Tektronix office. In the United States, call Tektronix at **1-800-835-6100**.

Extended features upgrade

In its standard configuration, the Phaser 300X offers 39 fonts and 10 Mbytes of RAM, with 14 or 22 Mbytes optional. With the Extended Features option, the Phaser 300X offers 22 Mbytes of memory, which increases general printer performance, PostScript processing performance, and throughput. The increased memory allows full Tabloid-bleed images on 12 x 18 in. media. The Extended Feature option also adds Ethernet connectivity as well as PhaserMatch, a custom profiler tool for Macintosh and PC platforms. PhaserMatch allows users to adjust printed colors for excellent accuracy and consistency. Included is an interactive, on-screen tutorial for the Macintosh.

Upgrades kits

- Z300X/B** Extended Features option.
- 4690F4M:** 4-Mbyte SIMM for adding memory. For more information about adding memory, see “Advantages of adding memory” on page B-3.
- 4680FP1:** Ethernet port upgrade kit; a SIMM that adds Ethernet hardware with EtherTalk and Novell protocols.

Note *The startup page reports how much memory is installed in the printer. For more information on upgrades, contact your local Tektronix dealer.*

Advantages of adding memory

The printer has 10 Mbytes of standard memory. You can upgrade the printer memory to 22 Mbytes by purchasing memory in 4-Mbyte SIMMs.

In general, more memory means improved imaging performance, improved network performance, high-resolution printing, and PCL5 emulation. Expanding printer memory also provides more storage for downloadable fonts.

- 14 Mbytes total: Provides additional input buffer memory. Allows you to print Tabloid-size bleed images on Tabloid Extra (12 x 18 in.) paper. The additional memory is required if you want maximum print area on Tabloid Extra paper. It is also required for Finepoint Sharpening.
- 18 Mbytes total: Provides additional input buffer memory and faster image processing.
- 22 Mbytes total: Provides additional input buffer memory and faster image processing; allows you to use PCL5 emulation; and enables full-Tabloid bleed images on Tabloid Extra (12 x 18 in.) media. PhaserMatch color profiler requires 22 Mbytes.

PhaserPrint

For printing in Unix environments, Tektronix offers PhaserPrint™. PhaserPrint provides fast raster file and screen copy printing to Tektronix color printers. PhaserPrint also provides a graphical user interface for push-button control of Tektronix printer features. PhaserPrint works with the workstation's native spooling system to print PostScript files and raster files in the Sun Raster Format (SRF), **xwd**, SGI RGB, and other formats. Refer to "Printing from a workstation" on page -16 for more information.

Note *To order PhaserPrint, use Tektronix order number 4690F20.*

PhaserSym

For printing in VMS environments, Tektronix offers PhaserSym™. PhaserSym is a VMS print symbiont for DEC OpenVMS VAX, and DEC OpenVMS AXP machines. PhaserSym facilitates communication between VMS hosts and Tektronix Phaser printers. PhaserSym requires that the Phaser printer include Ethernet support.

Note *To order PhaserSym, use Tektronix order number 4690F41.*

Adding a hard disk for font storage

You can connect one or more Small Computer System Interface (SCSI) external hard disks to the printer for additional font storage. When you download a font to an external disk, the font remains there until you remove it. In general, any disk that works with a LaserWriter NTX works with this printer.

You can order a 2.1 Gbyte external SCSI hard disk from Tektronix. Order number is **Z350DSK**.

To connect an external disk you need these items:

- A SCSI peripheral cable for each disk. The printer uses a high-density SCSI-II connector for connection to an external font storage hard disk. Standard SCSI-II cables are available from Tektronix; refer to “Interface cables and Ethernet adapters” on page 4.
- One SCSI cable terminator, unless your disk has an internal terminator.

The printer can support up to seven external disks. When connecting a hard disk to the printer, follow these guidelines:

Initialization Unless the disk is already formatted for operation with a PostScript printer, you have to initialize (format) the disk after connecting it to the printer. The Phaser 300X diskettes contain utility files to help you initialize the disk and download fonts to it. Refer to the *Phaser 300X Drivers and Utilities Printing Reference* for instructions on how to use the utility files.

SCSI ID number The printer's SCSI number is 7. Valid ID numbers for the external disk are 0 through 6.

Termination The printer has an internal terminator.

Start-up file You may load a start-up file called *Sys/Start* onto your external disk. When you turn on the printer, it executes that file if the printer's rear panel **Switch 5** is in the *down* position. When **Switch 5** is in the *up* position, the file does not execute.

Note *If the Sys/Start file contains an error, the printer ignores the remainder of the file and may not start up as you expect it to.*

Multiple disks The printer can support up to seven external disks. When you have more than one disk connected to the printer, follow these guidelines.

- You must turn on the disks before you turn on the printer.
- Each disk must have a unique SCSI ID number. Do not turn on the printer or disk until each disk has a unique number.
- The printer must always be at one end of the chain with a terminator at the other end.
- Only one disk can contain a *Sys/Start* file.

Connecting one disk

Turn off the computer, printer, and external disk before you connect or disconnect a SCSI cable.

1. Printer with a built-in SCSI terminator
2. SCSI port
3. External disk SCSI port
4. Terminator (not required if the disk has a built-in terminator).

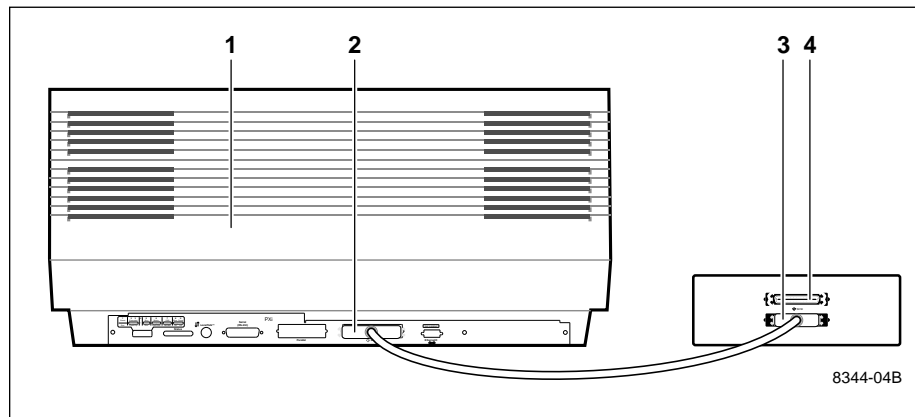

Connecting multiple disks

Turn off the computer, printer, and external disk before you connect or disconnect a SCSI cable.

1. Printer with a built-in SCSI terminator
2. SCSI port
3. External disks
4. Terminator (not required if the end disk has a built-in terminator; the middle disk must not have an internal terminator).

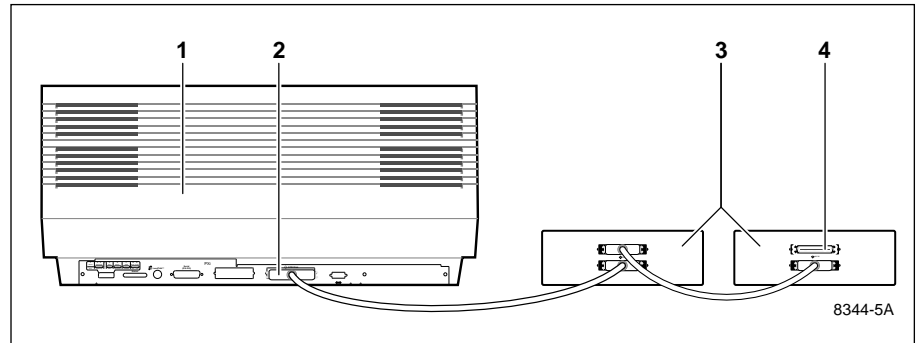

C

Moving Your Printer

After turning the printer off, Tektronix recommends that you let the printer cool down for a minimum of 20 minutes before moving it. This provides sufficient time so that the ink inside the printer has time to solidify.

Caution *Failure to allow enough cooling time for the ink to solidify can result in ink spills that may damage the printer's internal components.*

Keep the printer level as you move it. If you move the printer a long distance (transport it in a car or airplane), replace the shipping block to protect the printhead and empty the waste bin. See the topics "Emptying the waste bin" on page -5 and "Reinstalling the shipping block" on page C-2 for details.

Reinstalling the shipping block

Warning *The printhead remains hot for a while after you turn the printer off. To avoid injury, wait at least 20 minutes after turning the printer off before you do the following procedure.*

Refer to the drawing on the opposite page while following these steps.

1. Pull the wire (A) to move the printhead (B).
2. Push the tail piece (A) down and clip the bottom of the shipping block (B) to the rail.
3. Slide the shipping block toward the printhead (A). Firmly attach the shipping block to the printhead. Place the shipping block tightly (B) against the printhead.

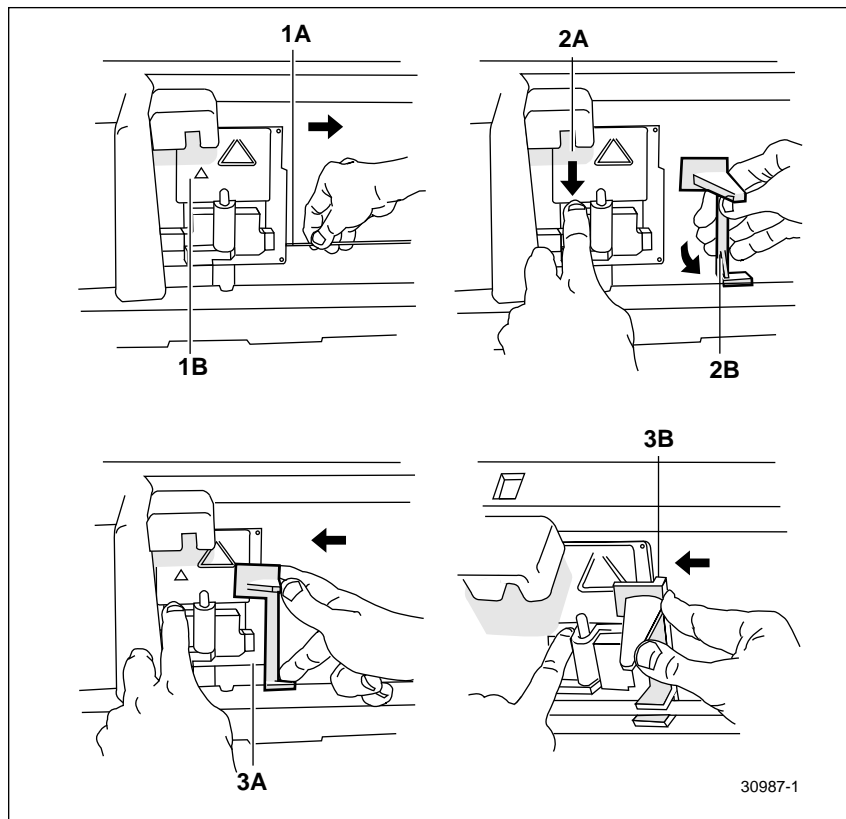

4. Press the tab (**A**) up, then push the printhead past the post (**B**).
5. Install the shipping block as shown.
6. Secure the red label to the shipping block with masking tape.
7. Close the cover.

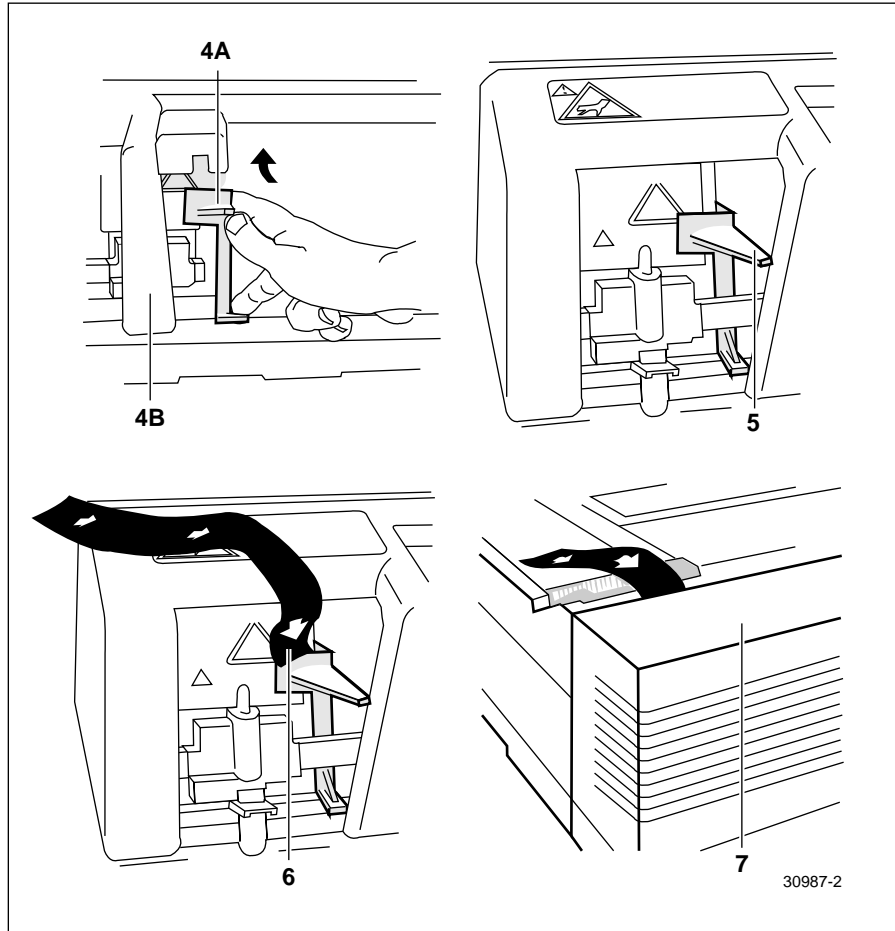

Changing line voltage

If you move the printer to a country that uses a line voltage different from the printer's factory setting, you can change the line voltage to the appropriate setting by using the line voltage selector switch.

Warning *Unplug the printer before changing the line voltage selector switch. For your safety, do not remove the cover from the printer. The line voltage selector switch is located next to the On/Off switch.*

Also, the new location may require a different power cord and fuse; see your dealer for details.

1. Line voltage selector switch.

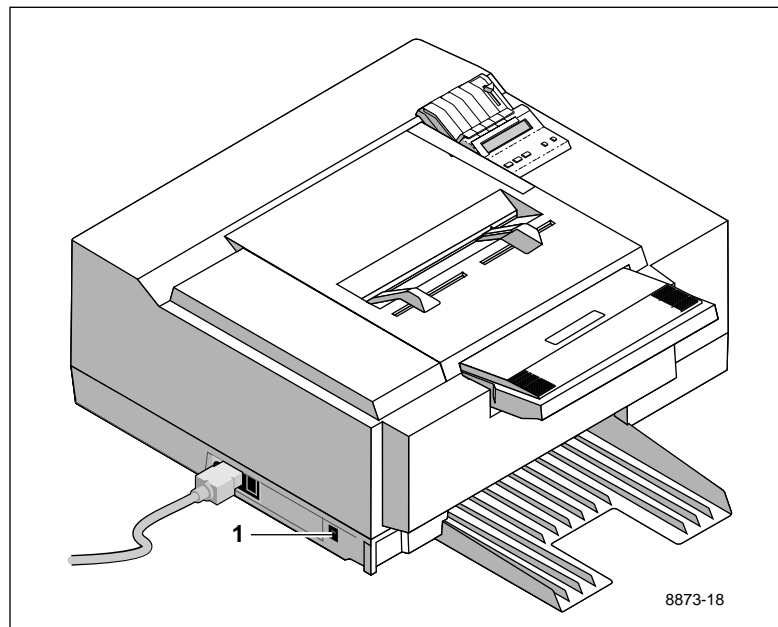

D

Regulatory Information

Declaration of conformity

Tektronix, Inc.
Color Printing and Imaging Division
P.O. Box 1000
Wilsonville, Oregon 97070-1000 U.S.A.

declares, under our sole responsibility, that the product

Phaser 300X

to which this declaration relates, is in conformity with the following standard(s) or other normative document(s):

For the EN55022:1986 Limits and Methods of measurement of radio interference characteristics of Information Technology Equipment. Class B level.

For the EN60555-2:1986 Disturbances in supply systems caused by for the black ink sticks appliances and similar electrical equipment. Part 2: Harmonics.

For the EN50082-1:1992 Electromagnetic compatibility Generic immunity standard Part 1: Residential, Commercial and Light Industry.

IEC801-2:1984

IEC801-3:1984

IEC801-4:1988

Following the provisions of the Electromagnetic Compatibility Directive 89/336/EEC.

For the EN60950 Safety of Information Technology Equipment including Electrical Business Equipment.

Following the provisions of the Low Voltage Directive 73/23/EEC.

Canadian EMC (Electromagnetic Compatibility) regulatory standards

- This digital apparatus does not exceed the Class B for radio noise emissions from digital apparatus set out in the Radio Interference Regulations of the Canadian Department of Communications.
- Le présent appareil numérique n'émet pas de bruits radioélectriques dépassant les limites applicables aux appareils numériques de la classe B prescrites dans le Règlement sur le brouillage radioélectrique édicté par le ministre des Communications du Canada.

FCC Class B warning (for 115 VAC equipment)

The equipment described in this manual generates and uses radio frequency energy. If it is not installed and used properly in strict accordance with Tektronix' instructions, it may cause interference with radio and television reception.

This equipment has been tested and found to comply with the limits for a Class B verified digital device, pursuant to Part 15 of the FCC Rules. These limits are designed to provide reasonable protection against harmful interference in a commercial environment. Operation of this equipment in a residential area is likely to cause harmful interference, in which case the user will be required to correct the interference at his own expense.

Changes or modification not expressly approved by Tektronix can affect emission compliance and could void the user's authority to operate this equipment.

Warning *Changes or modifications not expressly approved by Tektronix can affect emission compliance and voids the user's authority to operate this product.*

Material Safety Data Sheets

Proper management of environmental resources protects the well-being of our employees, customers, shareholders, and the communities we are a part of worldwide.

Tektronix establishes and maintains sound environmental management practices to accomplish this goal and to assure compliance with the laws, regulations, and orders of the responsible governmental authorities wherever Tektronix and its subsidiaries operate.

Tektronix, Incorporated is complying with government regulations by providing Material Safety Data Sheets for our products.

Color Printing and Imaging Division
Tektronix, Incorporated

Section I — Product identification

- **Trade name and Tektronix part number:**
*ColorStix Solid Ink — Black*016-1123-00
*ColorStix Solid Ink — Cyan*016-1124-00
*ColorStix Solid Ink — Magenta*016-1125-00
*ColorStix Solid Ink — Yellow*016-1126-00
- **CAS number:** Not applicable — mixture.
- **Product class:** Solid-ink formulation.
- **Ingredients:**
 Fatty amide waxes
 Rosin ester
 Phthalate Ester
 Black, cyan, magenta, or yellow dye
 Hazard ingredients: None (Per OSHA Hazard Communication Standard)

Section II — Emergency and first aid

General information: This product is a waxy solid and should not pose health hazards when used as intended.

Eye: Contact unlikely. Flush affected area thoroughly with water. If irritation develops, consult a physician.

Skin contact: Irritation unlikely; contact a physician if irritation develops and persists.

Inhalation: Not a likely route of entry.

Ingestion: Practically nontoxic as defined by the publication *Fundamentals of Toxicology* by Anderson and Scott, 1981.

Section III Toxicology and health information

TLV/PEL: None established. This product is not considered to be a hazardous chemical and can be considered an “article” as defined in 29 CFR 1910.1200.

Eye: Contact unlikely, but could cause irritation.

Skin contact: Irritation unlikely based on test results.

Inhalation: Not a likely route of entry.

Ingestion: Might result in gastric disturbance. Practically non-toxic.

Acute toxicological properties: Based on published LD₅₀ (rat) data for ingredients; LD₅₀ (rat) of mixture > 5g/kg. (Practically nontoxic)

Human patch test: Passed for irritation from long-term skin exposure.

Section IV — Physical data

Appearance and odor: Waxy solid, no odor. Black, blue (cyan), red (magenta), or yellow.
Boiling point: Not applicable.
Vapor pressure: Negligible.
Specific gravity: Approximately 0.93.

Section V — Fire and explosion data

Flash point: Approximately 240° C (464° F).
Flammable limits: No data available.
Extinguishing media: Dry chemical, water, or CO₂.
Special firefighting procedures: None.
Unusual fire and explosion hazards: None.

Section VI — Reactivity data

Stability: unstable ___ stable XXX.
Hazardous decomposition products: Information not available.
Incompatibilities (materials to avoid): None.
Hazardous polymerization: Will not occur.

Section VII — Special protection information

Respiratory protection: Not applicable.
Eye protection: Not applicable.
Protective gloves: Not applicable.

Section VIII — Special precautions

Handling and storage: None.
Conditions to avoid: High temperatures.

Section IX — Spill, leak, and disposal procedures

Spill or leak: Not applicable.
Disposal: This product is not a hazardous waste as specified in 40 CFR 261. Dispose in accordance with all federal, state, and local regulations.

Section X — Other regulatory information

TSCA: "Tektronix has a Low Volume Exemption under the Toxic Substances Control Act for the dye in the magenta ink stick. The magenta ink stick may be used only for commercial hot melt ink applications. We certify that all other components of these products are included in the Toxic Substances Control Act Chemical Substances Inventory as verified by our suppliers."

SARA: Not reportable.

CERCLA: No reportable quantity for this material.

RCRA: TCLP below hazardous waste levels set by EPA.

DOT: Not regulated.

NMFC: 101760 Sub. 3 - Ink, Printing, N.O.I., Class 55.

Original Preparation Date: 11/2/93 R.C.

Tektronix, Incorporated
P.O. Box 500
Chemical Documentation
Mail stop 55-769
Beaverton, Oregon 97077
Printer information: 1-800-835-6100
MSDS information: (503) 627-7255
Emergency: (503) 627-7255

Index

- A**
 - accessories, ordering 5-1, **B-1**
 - adding ink 4-2
 - adding memory **B-3**
 - Adobe IntelliSelect 3-40, 3-41
 - Adobe Photoshop 3-20
 - Adobe PostScript driver 3-8
 - alcohol, pre-soaked cloth 4-10
 - AppleTalk zones **A-4**
 - ASCII files, printing 3-16
 - automated information systems 3-18, 3-19, 6-1, 6-2
 - automatic language selection 3-40, 3-41
- B**
 - baud rate 2-12
 - BBS (Bulletin Board System) 2-17
 - black and white 6-25
 - buttons
 - CLEAN PRINT HEAD** 2-15, 7-2
 - front panel 2-15
 - TEST PRINT** 2-15, 7-2
- C**
 - cables, ordering 5-4
 - CD-ROM
 - drivers and utilities 2-17
 - installing software 2-17
 - PANTONE Colors** 1-3
 - change front panel language 2-15
 - change fuser wiper 4-4
 - changing languages 3-40
 - Chooser**, printer doesn't appear 6-20
 - CLEAN PRINT HEAD** 7-2
 - CLEAN PRINT HEAD** button
 - how to use 6-13
 - cleaning
 - paper jams 4-8
 - paper tension blade 4-15
 - Color Control Strip feature 1-3, 3-23
 - color correction 1-3, 3-4, 3-6, 3-8, 3-14, 3-22
 - color sampler charts 3-23
 - PhaserMatch 3-22
 - switches 3-22
 - utility file 3-22
 - color correction modes
 - Commercial** 3-22
 - Euroscale** 3-22
 - Simulate Display** 3-22
 - SWOP** 3-22
 - Use Printer Settings** 3-22
 - Vivid Blue** 3-22
 - color correction switches 3-22, 7-6
 - color sampler charts 3-23
 - ColorStix ink 1-4, 4-2, 5-1
 - COM port, setting up 2-19
 - Commercial Press** color correction 3-14
 - configuration page, generating **A-2**
 - connections
 - Ethernet 2-10
 - LocalTalk 2-8
 - parallel 2-11
 - serial 2-12
 - copy count **A-3**
 - Customer Support Hotline 6-1
- D**
 - default printer port settings 3-40
 - desktop printers, QuickDraw GX
 - printing from 3-15
 - device type **A-4**
 - diskettes, drivers and utilities 2-17
 - DOS
 - MODE** command 2-18, 2-19
 - printing from 3-10
 - downloading fonts 3-38

drivers
 using
 Macintosh 3-14
 Windows 3.1 3-8
 Windows 95 3-4, 3-6, 3-8

E

EasyCopy/X, workstation software 3-18
empty the waste bin 4-5
Enhanced print-quality mode 3-21
envelopes 3-35
error codes 6-3
ERROR indicator 7-3
Ethernet 2-10
 connecting 2-10
 problems 6-20
EuroHAL, automated fax system 6-1, 6-2
Euroscale Press color correction 3-14
Extended Features option 1-1, B-1
 PCL5 3-42
 PhaserMatch™ color profiler 3-22

F

features 1-1
 Color Control Strip 1-3, 3-23
 Finepoint Sharpening 3-21
 PhaserMatch™ color profiler 3-22
Finepoint Sharpening 3-21
fonts 1-2
 downloading 3-38
 resident typefaces 3-37
 TrueType 3-38
front panel 7-2
 buttons 2-15
 change language 2-15
 messages 6-3
 Utilities mode 2-15
ftp server 6-1
fuser wiper, changing 4-4

G

getting help 6-1
grade, papers 3-24
grain, paper 3-27

H

HAL, automated fax system 6-1, 6-2
 telephone number and instructions 6-2
hard disk B-5
 connecting multiple disks B-8
 connecting single disk B-7
 guidelines for multiple disks B-6
 Sys/Start file B-6
head convergence 6-8
 correcting 6-10
 setting 6-8
Hewlett-Packard Graphics Language
 (HP-GL) 1-2, 3-40
 setting parameters 3-43
 using 3-40
Highly Automated Library 3-18, 3-19

I

image area 1-4
indicators
 ERROR 7-3
 POWER 7-3
 rear panel 7-6
ink 4-2
 ColorStix ink sticks 1-4, 5-1
 cover 7-3
 INK LEVEL 4-2
 ink level icons 7-2
 ink sticks 4-2
 load level 7-3
 loading 4-2
 purging 6-13, 6-14
ink sticks 1-4, 5-1

- installation 2-17
 - at a glance 2-1
 - connecting the printer 2-7
 - setting up DOS computer ports 2-19
 - setting up the printer 2-6
- installing
 - printer software 3-8
 - screen fonts 3-39
- IntelliSelect 3-41
- Internet access 6-1
- inventory 2-2
- isopropyl alcohol 4-10

J

- jams, clearing 6-5

L

- landscape orientation 3-30
- languages, front panel 2-15
- large paper, loading 3-34
- leave printer on 2-14
- line voltage, changing C-4
- loading ink 4-2
- loading paper 2-4, 3-32
 - letterhead 3-33
 - manual feed 3-34
 - paper trays 3-32
 - small paper 3-35
 - three-holed paper 3-33
- loading transparencies 3-36
- LocalTalk
 - cables and termination 2-8
 - connecting 2-8
 - problems 6-20
- LPT port, setting up 2-19

M

- Macintosh printer driver
 - Page Setup** dialog box 3-14
 - Print** dialog box 3-14
 - TekColor Options** dialog box 3-14
- Macintosh screen fonts, install 3-39
- maintenance, schedule 4-1
- manual feed 3-4, 3-6, 3-8, 3-14, 3-34
 - envelopes 3-35
 - paper 3-35
 - transparencies 3-36
- margins 3-28
- media 3-24
- media switch 2-6
- memory
 - advantages of adding B-3
 - Extended Features option 1-3, B-1
 - image area 1-4, B-1
- memory upgrades B-3
- Microsoft Windows NT PostScript printer
 - driver, updating 3-10
- missing lines on print 6-13
- MODE** command 2-18, 2-19
 - setting up ports 2-19
- Monochrome** color correction 3-14
- moving the printer C-2

N

- network option 2-10
- network problems 6-20
- No color correction** 3-14
- NT, Windows NT PostScript printer driver,
 - updating 3-10
- number of prints made A-3

O

- on/off switch 2-14
- online services 6-1
- options
 - Extended Features 1-1, B-1
 - PCL5 3-38
- ordering cables 5-4
- ordering supplies 1-4, 5-1
 - cleaning 5-1
- orientation
 - landscape 3-30
 - paper 3-30
 - portrait 3-30
- output tray
 - installing 2-5

P

- Page Setup** dialog box 3-14
- PANTONE Colors 3-19
- paper 3-24
 - dimensions 3-25
 - grade and finish 3-24
 - grain 3-27
 - input method 3-25
 - recycle 3-24
 - size 3-25
 - thickness 3-25, 3-26
 - weight 3-26
 - what you can use 3-24
- paper jams 4-8
 - cleaning 4-8
 - clearing 6-5
- paper sizes 1-4, 3-25
- paper tension blade, cleaning 4-15
- paper trays 3-32
- parallel
 - connection 2-11
 - printer port A-5
- parallel port
 - connecting 2-11
- MODE** command A-5
 - signals A-5
- PCL5 1-2, 3-38, 3-40, 3-42
 - printing 3-42
- Phaser 300X CD-ROM 2-17
- Phaser 300X diskettes 2-17
 - color correction 3-23
- PhaserMatch™ color profiler 1-1, 1-3, 3-22
- PhaserPrint B-4
 - order number B-4
- PhaserSym
 - capabilities B-4
 - order number B-4
 - software for workstations 3-18
- platforms 3-1
- portrait orientation 3-30
- ports
 - computer 2-19
 - printer 2-7
 - printer speed 2-10
 - setting up 2-18, 2-19
- PostScript 3-40
 - PostScript Header
 - Windows 3.1 driver 3-9
 - Windows 95 driver 3-5, 3-7
- POWER indicator 7-3
- power on printer 2-14
- Premium** print-quality mode 3-21
- pre-soaked alcohol cloth 4-10
- print area 3-28
- print count A-3
- Print** dialog box 3-14
- print features, selecting 3-21
- print quality 3-4, 3-6, 3-8, 3-14
- Printer Command Language 1-2, 3-40, 3-42

- printer drivers
 - using
 - Macintosh 3-14
 - Windows 3.1 3-8
 - Windows 95 3-4, 3-6, 3-8
- printer languages 3-41
 - HP-GL 3-40
 - PCL5 3-40
 - PostScript 3-40
 - switching 3-41
- printer name A-4
- printer ports 2-7
 - parallel A-5
- printer service 6-1
- printer software, installing 3-8
- printer standby modes 6-23
- printer status display 7-2
- printer, paper jams 4-8
- PRINTER.INF, updating Windows NT driver 3-10
- printing menu, QuickDraw GX printer driver
 - Start Print Queue** command 3-15
 - Stop Print Queue** command 3-15
- print-quality modes 3-21
- problems
 - LocalTalk 6-20
 - network 6-20
 - print quality 6-13
 - wrinkled edges 6-22
- purge ink 6-13

Q

- QuickDraw GX printer driver
 - printing from
 - GX-aware applications 3-15
 - non-GX aware applications 3-15
 - printing menu
 - Start Print Queue** command 3-15
 - Stop Print Queue** command 3-15

R

- rear panel indicators 7-6
- rear panel switches 2-6, 2-12, 3-22
 - color correction 3-22
 - media, US or Metric 3-28
- recycle paper 3-24
- reinstalling the shipping block C-2
- removing the shipping block 2-3
- resident typefaces
 - PCL5 3-37
 - PostScript 3-37

S

- screen fonts
 - installing 3-39
 - Macintosh 3-39
- SCSI disk B-5
 - connecting multiple disks B-8
 - connecting single disk B-7
 - guidelines for multiple disks B-6
 - initialization B-5
 - Sys/Start* file B-6
- SCSI port 2-7
 - ID number B-6
 - termination B-6
- select a port (DOS) 2-18
- selecting print-quality mode 3-21
- serial connection 2-12
- serial port 2-19
 - connecting 2-12
 - signals A-8
- set margins 3-28
- setting up PC ports (DOS) 2-18
- shipping block
 - reinstalling C-2
 - removing 2-3
- Simulate Display** color correction 3-14
- size, paper 3-25
- small paper 3-35
- smaller print size than expected 6-24

- solid ink 1-1
- Standard** print-quality mode 3-21
- startup page 6-28
 - disable 2-14
- supplies, ordering 1-4, 5-1
- switches
 - baud rate 2-12
 - color correction 3-22
 - media 2-6
- SWOP Press** color correction 3-14
- Sys/Start* file B-6

T

- TekColor Dynamic Correction 1-3, 3-22
- Tektronix Bulletin Board Service (BBS) 6-1
- Tektronix Bulletin Board System (BBS) 2-17
- TEST PRINT button 7-2
- test print, printing 2-16
- thickness, paper 3-26
- timeouts, Windows 95 driver 3-4, 3-6, 3-8
- Transmission Retry, Windows 3-4, 3-6, 3-8
- transparencies, loading 3-36
- trays, paper, selecting 3-4, 3-6, 3-8, 3-14
- TrueType fonts 3-38
- turn on printer 2-14

U

- Use Printer Setting** color correction 3-14
- used ink 4-5
- using EuroHAL 6-1
- Utilities** mode 2-15, 7-2
 - menu structure 7-4

V

- Vivid Color** color correction 3-14

W

- waste bin 4-5
- weight, paper 3-26
- Windows 3.1 driver
 - Features tab 3-8
 - Job Control tab 3-9
 - Paper tab 3-8
 - PostScript header 3-9
 - PostScript tab 3-9
 - using 3-8
- Windows 95 driver
 - Details tab 3-4, 3-6
 - Device Options tab 3-5, 3-7
 - Graphics tab 3-4, 3-6
 - Paper tab 3-4, 3-6
 - PostScript Header 3-5, 3-7
 - PostScript tab 3-5, 3-7
 - timeouts 3-4, 3-6, 3-8
 - using 3-4, 3-6, 3-8
- wiper, cleaning 4-20
- workstation software
 - EasyCopy/X 3-18
 - PhaserPrint 3-17, B-4
 - PhaserSym 3-18
- World Wide Web
 - home page address 6-1
 - printer information 3-18, 3-19
- wrinkled edges on the print 6-22

Z

- zones A-4